

# ADECON Controls

- Adecon Contactor
- Adecon Inverter
- Adecon Starter

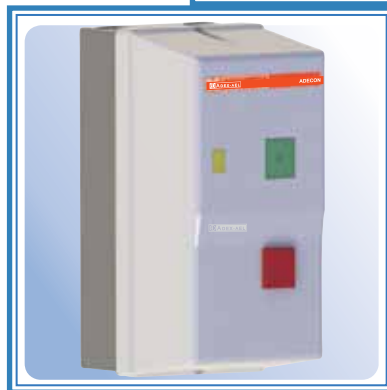

# Contactors, Control Relays & Accessories

Conforming to IEC 60947-5-1



		AX3-006	AX3-009	AX3-012	AX3-018	AX3-025
Maximum rated operational voltage		660V	690V	690V	690V	690V
Maximum rated current for motor control (3 phase 415V, 50/60Hz, for AC3 Duty)		AC15 duty (IEC 947-5-1) AC11 duty (IEC 851-6) 6A at 500V	9A	12A	18A	25A
Maximum standard power rating for motor control for AC3 duty $\theta \leq 55^{\circ}\text{C}$ , 415V			kW / hp	kW / hp	kW / hp	kW / hp
			4 / 5.5	5.5 / 7.5	9 / 12.5	11 / 15
3 ~ AC3	230V HP	-	3	3	5	7.5
	460/480V HP	-	5	7.5	10	15
	575V HP	-	7.5	10	15	20
Mounting position (w.r.t. normal vertical mounting plane)		$\pm 30^{\circ}$	$\pm 30^{\circ}$	$\pm 30^{\circ}$	$\pm 30^{\circ}$	$\pm 30^{\circ}$
Maximum thermal current /th ( $\theta \leq 40^{\circ}\text{C}$ )		10A	25A	25A	32A	40A
Maximum operating rate AC		10800	3600	3600	3600	3600
(operations / hr) DC		3600	3600	3600	3600	3600
Average coil consumption (inrush/sealed)	50 Hz	60 / 7 VA	60 / 7 VA	60 / 7 VA	60 / 7 VA	90 / 75 VA
	60Hz	60 / 7.5 VA	60 / 7.5 VA	60 / 7.5 VA	60 / 7.5 VA	90 / 8.5 VA
	50/60 Hz	70 / 8 VA	70 / 8 VA	70 / 8 VA	70 / 8 VA	100 / 8.5 VA
	DC	9 / 9W	9 / 9W	9 / 9W	9 / 9W	11 / 11W
Heat dissipation at	50 and 60Hz	2 to 3W	2 to 3W	2 to 3W	2 to 3W	2.5 to 3.5W
	DC	9W	9W	9W	9W	11W
Mechanical life (in millions of operations)	AX3 50 or 60 Hz	30	20	20	20	16
	50/60 Hz	20	15	15	15	12
	AX3	30	30	30	30	25
Power contact terminal capacity mm <sup>2</sup>		2.5	4	4	6	10
Over-all dimensions in mm	AC					
		80mm	80mm	80mm	85mm	93mm

Add-on Blocks  
 - auxiliary contact blocks  
 - Time delay contact blocks  
 - Latch add-on blocks

Auxiliary  
 contact block  
 (side mounted)

Auxiliary  
 contact block  
 (front mounted)

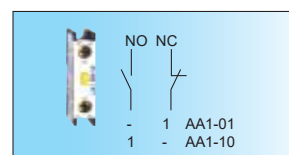

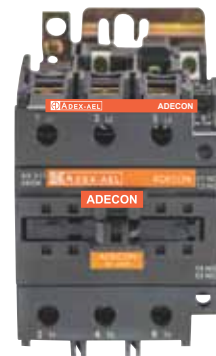
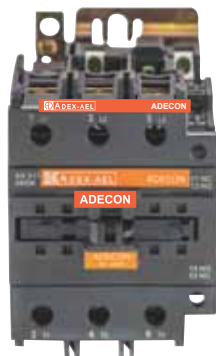

AX3-032	AX3-040	AX3-050	AX3-065	AX3-080	AX3-095	AD3-115
690V	690V	690V	690V	690V	690V	1000V
32A	40A	50A	65A	80A	95A	115A
kW / hp	kW / hp	kW / hp	kW / hp	kW / hp	kW / hp	kW / hp
15 / 20	22 / 30	25 / 35	37 / 50	45 / 60	45 / 60	59 / 80
10	10	15	20	30	30	40
20	30	40	50	60	60	75
25	30	40	50	60	60	100
± 30°	± 30°	± 30°	± 30°	± 30°	± 30°	± 30°
50A	60A	80A	80A	125A	125A	200A
3600	3600	3600	3600	3600	3600	2400
3600	3600	3600	3600	3600	-	2400
90 / 75 VA	200 / 20 VA	200 / 20 VA	200 / 20 VA	200 / 20 VA	200 / 20 VA	550 / 45 VA
90 / 8.5 VA	200 / 22 VA	200 / 22 VA	200 / 22 VA	200 / 22 VA	200 / 22 VA	660 / 55 VA
100 / 8.5 VA	245 / 26 VA	245 / 26 VA	245 / 26 VA	245 / 26 VA	245 / 26 VA	-
11 / 11W	22 / 22W	22 / 22W	22 / 22W	22 / 22W	-	560 / 4.5W
2.5 to 3.5W	6 to 10W	6 to 10W	6 to 10W	6 to 10W	6 to 10W	12 to 16W
11W	22W	22W	22W	22W	-	4.5W
16	16	16	16	10	10	10
12	6	6	6	4	4	-
25	20	20	20	20	20	10
10	25	25	25	50	50	95
98mm	114mm	114mm	114mm	125mm		

Auxiliary contact block (front mounted)

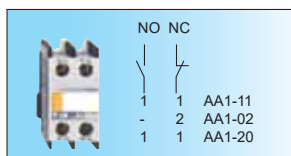

Auxiliary contact block (front mounted)

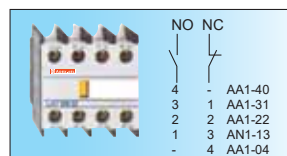

**Coil Reference**

	24V	110V	220V	415V
AC	3	5	7	9
DC	3D	5D	7D	9D



AD3-150	AD3-185	AD3-225	AD3-265	AD3-330	AD3-400	AD3-500	AD3-630
1000V	1000V	1000V	1000V	1000V	1000V	1000V	1000V
150A	185A	225A	265A	330A	400A	500A	630A
kW / hp	kW / hp	kW / hp	kW / hp	kW / hp	kW / hp	kW / hp	kW / hp
80 / 108	100 / 136	100 / 148	140 / 190	180 / 240	200 / 300	280 / 380	375 / 500
50	60	75	75	100	125	200	300
100	125	150	150	200	250	400	600
125	150	150	200	250	300	500	800
± 30°	± 30°	± 30°	± 30°	± 30°	± 30°	± 30°	± 30°
250A	275A	315A	350A	400A	500A	700A	1000A
2400	2400	2400	2400	2400	2400	2400	1200
2400	2400	2400	2400	2400	2400	2400	1200
550 / 45 VA	805 / 55 VA	805 / 55 VA	1200 / 95 VA	700 / 10 VA	1075 / 15 VA	1100 / 18 VA	1650 / 22 VA
660 / 55 VA	970 / 66 VA	970 / 66 VA	1445 / 110 VA	700 / 10 VA	1075 / 15 VA	1100 / 18 VA	1650 / 22 VA
-	-	-	-	700 / 10 VA	1075 / 15 VA	1100 / 18 VA	1650 / 22 VA
560 / 4.5W	800 / 5W	800 / 5W	750 / 5W	750 / 5W	1000 / 6W	1100 / 6W	1600 / 9W
12 to 16W	18 to 24W	18 to 24W	30 to 40W	12	14W	18W	20W
4.5W	5W	5W	5W	-	6W	6W	9W
10	10	10	10	10	10	10	5
-	-	-	-	10	10	10	5
10	10	10	10	10	10	10	5
120	150	185	240	240	2 x 150	2 x 240	2 x 60 x 5

Off delay timer block (front mounted)

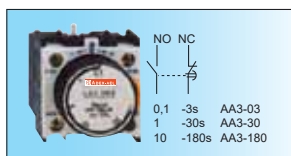

On delay timer block with switching time of 40ms ± 15ms between opening of N/C contact to closing of N/O contact (front mounted)

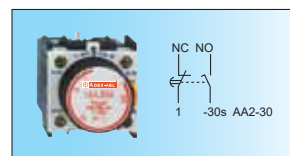

Latch add-on block (front mounted)

**AX311-Range Contactor Selection Guide** (according to the required electrical life)

**Category AC-1**  
 ( $U_e \leq 440V$ ). Control of resistive circuits ( $\cos \phi \geq 0.95$ ). The current broken ( $I_c$ ) in category AC-1 is equal to the current ( $I_e$ ) normally drawn by the load.

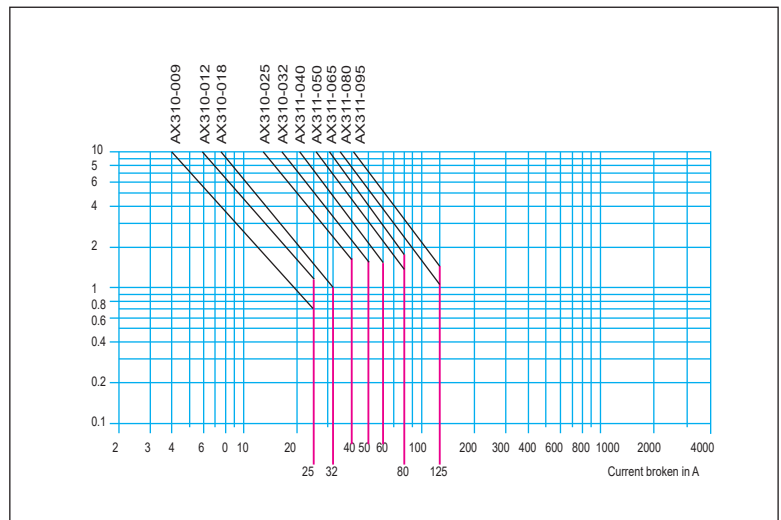

**Category AC - 3**  
 ( $U_e \leq 440 V$ ). Control of squirrel cage motors with breaking whilst motor running. The current broken ( $I_c$ ) in category AC-3 is equal to the current ( $I_e$ ) normally drawn by the load.

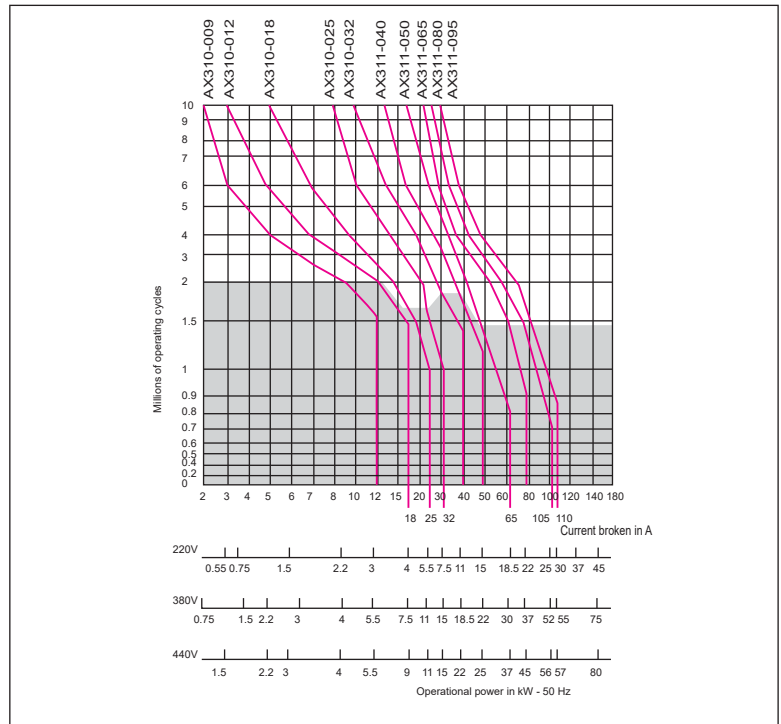

**Category AC-4**  
 ( $U_e \leq 440V$ ). Control of 3-phase asynchronous squirrel cage (AC-4) or slip ring (AC-2) motors with breaking whilst motor stalled. The current broken in category AC-4 is equal to  $6 \times I_e$ . ( $I_e$ =rated operational current of the motor).

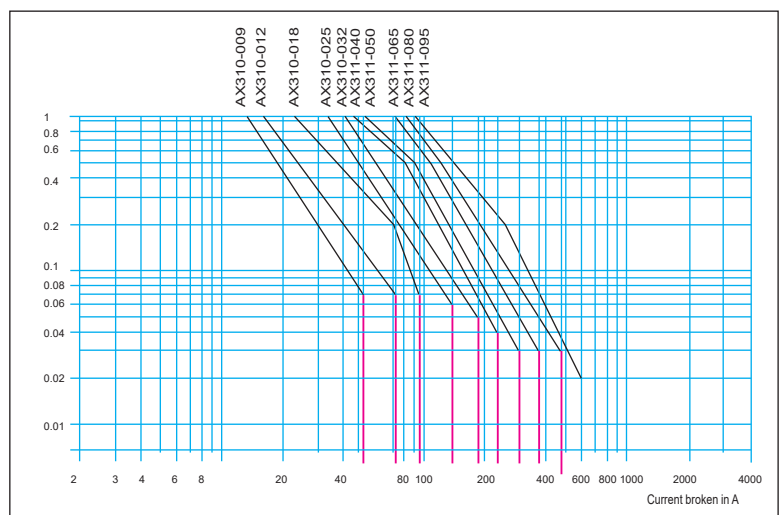

**Relay Selection table (Type AR132,AR223 & AR630) - These relays can be automatic or manual reset**

Relay Reference	Relay Setting Range (A)	STANDARD POWER RATINGS OF 3-PHASE MOTORS 50/60Hz, AC3 CATEGORY					Back Up Fuse Rating g1(A)
		220V	380V	415V	440V	600	
		KW	KW	KW	KW	KW	
AR132-001101	0.1 to 0.16	*	*	*	*	*	2
AR132-001102	0.16 to 0.25	*	*	*	*	*	2
AR132-001103	0.25 to 0.4	*	*	*	*	*	2
AR132-001104	0.4 to 0.63	*	*	*	*	0.37	2
AR132-001105	0.63 to 1	*	*	*	*	0.55	4
AR132-106206	1 to 1.6	*	0.37	*	0.55	1.1	4
AR132-106207	1.6 to 2.5	0.3	0.75	1.1	1.1	1.5	6
AR132-205040	2.5 to 4	7	1.5	1.5	1.5	3	10
AR132-004060	4 to 6	0.75	2.2	2.2	2.2	4	16
AR132-505080	5.5 to 8	1.1	3	3.7	3.7	5.5	20
AR132-007080	7 to 10	1.5	4	4	4	7.5	20
AR132-009013	9 to 13	2.2	5.5	5.5	5.5	10	25
AR132-012018	12 to 18	3	7.5	9	9	15	35
AR132-017025	17 to 25	4	11	11	11	18.5	50
AR223-023032	23 to 32	5.5	15	15	15	*	63
AR223-028036	28 to 36	7.5	15	18.5	18.5	*	80
AR223-037050	37 to 50	9	22	25	25	37	100
AR223-048065	48 to 65	11	25	30	30	50	100
AR223-080093	80 to 93	18.5	45	49	50	80	160
AR539-090150	90 to 150	25	80	80	90	140	250
AR630-000065	48 to 65	45	25	37	37	55	100
AR630-000070	55 to 70	20	30	40	40	59	125
AR630-000080	63 to 80	22	33	49	50	80	125
AR630-000093	80 to 93	25	45	55	59	90	160
AR630-000105	65 to 105	25	51	59	63	110	160
AR630-000125	80 to 125	30	59	80	90	140	200
AR630-000160	100 to 160	45	80	100	110	160	250
AR630-000200	125 to 200	55	90	129	140	200	315
AR630-000250	160 to 250	63	110	160	160	257	400
AR630-000315	200 to 315	80	150	200	220	335	500
AR630-000400	250 to 400	110	185	257	280	445	630
AR630-000500	315 to 500	140	250	355	375	500	800
AR630-000630	400 to 630	180	315	425	450	-	800

\* For Independent Mounting

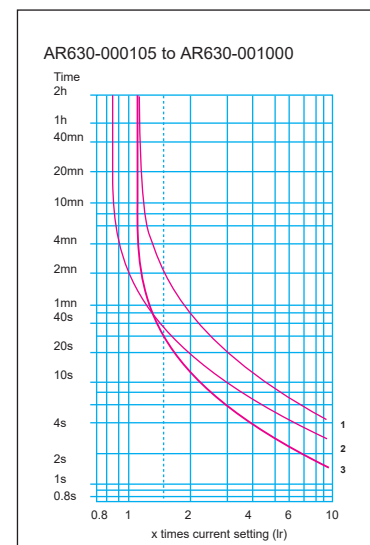
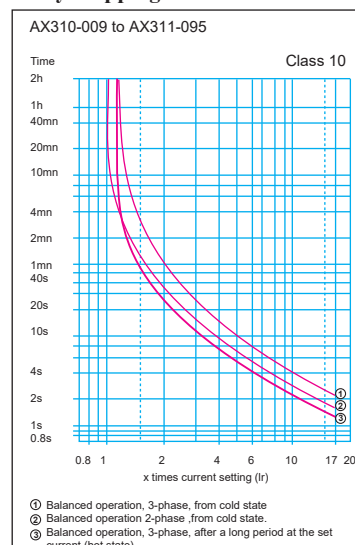
**Relay Tripping Curves**

## Adecon Inverter

### Adecon Inverters

Adecon frequency inverter series incorporates high technological software & integrated hardware designed for complex load requirements. With advanced space voltage vector, SPWM control technology achieves high-accuracy closed loop control by high-powered IGBT-DSP chip and built-in current control loop. It can attain high accuracy requirement on output voltage & frequency. Brand-new production craft and optional equipments ensure the high working stability and offer you better motor control solution.

- Brand-new software & hardware design.
- High quality assurance
- Aesthetic look
- DSP based IGBT achieves high-efficiency & high-powered control.
- V/F and V/F+PG control functions for AI7800 & AI8000 series
- Vector and Vector+PG control functions for AI9000 series
- 3 types of space voltage vector wave produce mode
- Dead zone compensation function achieves low frequency high power output
- Automatic slip compensation
- 10 methods to set frequency, imitation terminals can accept user defined signal within (0-10V) & (0-20mA.)
- Multi segment speed control facility
- Built-in PID control function, achieves high-powered close loop control.
- Supports 0-10V, 1-5V,0-20mA,4-20mA feedback signal.
- PID based DC brake.
- Speed tracking at starting and restart after momentary power loss
- Strong communication function, supports standard RS485 and CanBus with remote keyboard input function (optional).
- User friendly display list, LCD display with LED, displays 3 status parameter.
- Particular IGBT temperature rise supervising function, adjusts the fan, and reduce the motor noise and temperature rise duly.
- High-efficiency failure checking and recording function, facilitates rectification of fault.
- Punctional parameters for monitoring the process and degree of protection.
- Unique design to reduce the pollution to power
- Auto tuning facility.
- Auto torque boost control for too heavy loads.
- Large torque at low speed for stable operation for AI9000 series
- Minimum torque response time (0-20ms) and fast current limiting function for trip free operation for AI9000 series
- Smooth acceleration and deceleration profile
- Low requirements even in hostile working environments
- Easily compatible with PLC, ammeter, frequency meter and other instruments.



## Adecon Inverter

AI - 8000/8100 Series Frequency Inverter 380-500V G4/F3  
0.75-7.5kW



AI-8100 G4 General series V/F control (380-500V, 3 phase input & output)

AI No	Model No	Voltage (V)	Power (kW)	Current (A)	Key Model
1	AI-8100A - R75G4	380-500	0.75	2.5	AC6E8100
2	AI-8100A - 1R5G4	380-500	1.5	3.7	AC6E8100
3	AI-8100A - 2R2G4	380-500	2.2	5	AC6E8100
4	AI-8100A - 004G4	380-500	4	8.5	AC6E8100
5	AI-8100A - 5R5G4	380-500	5.5	13	AC6E8100
6	AI-8100A - 7R5G4	380-500	7.5	16	AC6E8100



AI-8100 F3 General series V/F control (380-460V, 3 phase input & output)

AI No	Model No	Voltage (V)	Power (kW)	Current (A)	Key Model
1	AI-8100A - R75F3	380-460	0.75	2.5	AC6E8100
2	AI-8100A - 1R5F3	380-460	1.5	3.7	AC6E8100
3	AI-8100A - 2R2F3	380-460	2.2	5	AC6E8100
4	AI-8100A - 004F3	380-460	4	8.5	AC6E8100
5	AI-8100A - 5R5F3	380-460	5.5	13	AC6E8100
6	AI-8100A - 7R5F3	380-460	7.5	16	AC6E8100

## AI-7800 Series Frequency Inverter 380-460V G3

11-630kW



AI-7800 G3 General series V/F control (380-460V, 3 phase input & output)

AI No	Model No	Voltage (V)	Power (kW)	Current (A)	Key Model
1	AI-7800 011G3	380-460	11	25	AC6E7800
2	AI-7800 015G3	380-460	15	32	AC6E7800
3	AI-7800 018G3	380-460	18	38	AC6E7800
4	AI-7800 022G3	380-460	22	45	AC6E7800
5	AI-7800 030G3	380-460	30	60	AC6E7800
6	AI-7800 037G3	380-460	37	75	AC6E7800
7	AI-7800 045G3	380-460	45	90	AC6E7800
8	AI-7800 055G3	380-460	55	110	AC6E7800
9	AI-7800 075G3	380-460	75	150	AC6E7800
10	AI-7800 093G3	380-460	93	170	AC6E7800

## Adecon Inverter

AI - 7800 Series Frequency Inverter 380-460V G4/F3  
11-630kW



AI- 7800 G4 General series V/F control (380-500V, 3 phase input & output)					
AI No	Model No	Voltage (V)	Power (kW)	Current (A)	Key Model
11	AI-7800 110G4	380-500	110	210	AC6E7800
12	AI-7800 132G4	380-500	132	250	AC6E7800
13	AI-7800 160G4	380-500	160	300	AC6E7800
14	AI-7800 132G4	380-500	132	250	AC6E7800
15	AI-7800 160G4	380-500	160	300	AC6E7800
16	AI-7800 187G4	380-500	187	340	AC6E7800
17	AI-7800 200G4	380-500	200	380	AC6E7800
18	AI-7800 220G4	380-500	220	415	AC6E7800
19	AI-7800 250G4	380-500	250	470	AC6E7800
20	AI-7800 280G4	380-500	280	520	AC6E7800
21	AI-7800 315G4	380-500	315	600	AC6E7800
22	AI-7800 355G4	380-500	355	640	AC6E7800
23	AI-7800 400G4	380-500	400	750	AC6E7800
24	AI-7800 450G4	380-500	450	860	AC6E7800
25	AI-7800 500G4	380-500	500	920	AC6E7800
26	AI-7800 560G4	380-500	560	988	AC6E7800
27	AI-7800 630G4	380-500	630	1100	AC6E7800



AI- 7800 F3 General series V/F control (380-460V, 3 phase input & output)					
AI No	Model No	Voltage (V)	Power (kW)	Current (A)	Key Model
1	AI-7800 015F3	380-460	15	32	AC6E7800
2	AI-7800 018F3	380-460	18	38	AC6E7800
3	AI-7800 022F3	380-460	22	45	AC6E7800
4	AI-7800 030F3	380-460	30	60	AC6E7800
5	AI-7800 037F3	380-460	37	75	AC6E7800
6	AI-7800 045F3	380-460	45	90	AC6E7800
7	AI-7800 055F3	380-460	55	110	AC6E7800
8	AI-7800 075F3	380-460	75	150	AC6E7800
9	AI-7800 093F3	380-460	93	170	AC6E7800
10	AI-7800 110F3	380-460	110	210	AC6E7800
11	AI-7800 132F3	380-460	132	250	AC6E7800
12	AI-7800 160F3	380-460	160	300	AC6E7800
13	AI-7800 132F3	380-460	132	250	AC6E7800
14	AI-7800 160F3	380-460	160	300	AC6E7800
15	AI-7800 187F3	380-460	187	340	AC6E7800
16	AI-7800 200F3	380-460	200	380	AC6E7800
17	AI-7800 220F3	380-460	220	415	AC6E7800
18	AI-7800 250F3	380-460	250	470	AC6E7800
19	AI-7800 280F3	380-460	280	520	AC6E7800
20	AI-7800 315F3	380-460	315	600	AC6E7800
21	AI-7800 355F3	380-460	355	640	AC6E7800
22	AI-7800 400F3	380-460	400	750	AC6E7800
23	AI-7800 450F3	380-460	450	860	AC6E7800
24	AI-7800 500F3	380-460	500	920	AC6E7800
25	AI-7800 560F3	380-460	560	988	AC6E7800
26	AI-7800 630F3	380-460	630	1100	AC6E7800

## Adecon Inverter

AI-9••• Series Frequency inverter 180-240V (G1) & 380-460V (G3)

0.75-355kW



### AI- 9100- G1 General Series Vector Control Inverter (180-240V, single phase input & 3 phase output)

AI	Model No	Voltage (V)	Power (KW)	Current (A)	Key Model
1	AI-9100A - R75G1	180-240	0.75	4	AC6E9100
2	AI-9100A - 1R5G1	180-240	1.5	7	AC6E9100
3	AI-9100A - 2R2G1	180-240	2.2	10	AC6E9100
4	AI-9100A - 004G1	180-240	4	16	AC6E9100

### AI- 9000- G3 General Series Vector Control Inverter (380- 460V, three phase input & output) Adecon I- 9100 (0.75kW ~ 7.5kW)

AI	Model No	Voltage (V)	Power (kW)	Current (A)	Key Model
1	AI-9100A - R75G3	380-460	0.75	2.1	AC6E9100
2	AI-9100A - 1R5G3	380-460	1.5	3.8	AC6E9100
3	AI-9100A - 2R2G3	380-460	2.2	5.1	AC6E9100
4	AI-9100A - 004G3	380-460	4	9	AC6E9100
5	AI-9100A - 5R5G3	380-460	5.5	13	AC6E9100
6	AI-9100A - 7R5G3	380-460	7.5	17	AC6E9100

### AI- 9200 (11kW ~ 160kW)

7	AI-9200 011G3	380-460	11	25	AC6E9200
8	AI-9200 015G3	380-460	15	32	AC6E9200
9	AI-9200 018G3	380-460	18	37	AC6E9200
10	AI-9200 022G3	380-460	22	45	AC6E9200
11	AI-9200 030G3	380-460	30	60	AC6E9200
12	AI-9200 037G3	380-460	37	75	AC6E9200
13	AI-9200 045G3	380-460	45	90	AC6E9200
14	AI-9200 055G3	380-460	55	110	AC6E9200
15	AI-9200 075G3	380-460	75	150	AC6E9200
16	AI-9200 093G3	380-460	93	176	AC6E9200
17	AI-9200 110G3	380-460	110	210	AC6E9200
18	AI-9200 132G3	380-460	132	253	AC6E9200
19	AI-9200 160G3	380-460	160	304	AC6E9200

### AI-9300 (187kW~355kW)

20	AI-9300 187G3	380-460	187	340	AC6E9300
21	AI-9300 200G3	380-460	200	380	AC6E9300
22	AI-9300 220G3	380-460	220	426	AC6E9300
23	AI-9300 250G3	380-460	250	465	AC6E9300
24	AI-9300 280G3	380-460	280	520	AC6E9300
25	AI-9300 315G3	380-460	315	585	AC6E9300
26	AI-9300 355G3	380-460	355	650	AC6E9300



## Applications:

Technologically advanced Adecon inverters have a wide area of application, such as petrochemical industry, pharmaceuticals, cement, steel re-rolling, textile & garments, plastic & packaging, food & beverage, ceramics, spinning mills, paper mills, concrete, injection machine, public works, water supply, sewage treatment etc. Besides "G" (general) type, we also have some special types of inverters according to different applications.

- **VFD special for multi-pump constant water supply**

Advanced control theory, built-in PID and multi-pump operation control logic controller, can adjust pump speed and pump switching automatically according to the variation of pipe network pressure, then achieves constant pressure control of the pipe network.

- **Inversion power special for motor**

To ensure continuous production process during sudden electricity failure, it connects to the load circuit at first time, and outputs the motor-required voltage and frequency via motor speed inertia function, then makes the motor continue running stably.

- **VFD special for machine tool**

When motor runs in low speed and requires high torque and speed accuracy, it automatically detect motor dynamic running parameter and adjust accordingly, to ensure the motor run under high efficiency

- **VFD special for compressor**

High over-load and over-current capacity, easily meets the compressor heavy load and auto-constant pressure requirement. Various input output ports can receive various pressure return signal, achieves close loop control via PID adjustment

- **VFD special for injector**

Very high over-load and over-current capacity, easily meets the injector's rapid frequently start and brake functions. Various input output ports, facilitates the combination with injector controller & easily achieve automatic control

- **Motor Pro-environment Energy Saving machine**

It has got a wide application, such as petrochemical industry, cement, steel re-rolling, textile & garments, plastic & packaging, food & beverage, ceramics, spinning mills, paper mills, electric, public works, water supply, sewage treatment, for motor speed adjustment and energy saving

- **Power control system special for metallurgy mixer**

DSP control close-loop self-regulation function, various working mode such as constant mixing/ positive-reverse alternative mixing. Can set or adjust output frequency and output current independently. Widely applied in many filed such as metallurgy continuous casting and special steel and aluminum smelting etc.



## Industrial applications

### Optimum control in general industrial applications

- Soft starting, variable speed and intelligent process control comes as standard. Adecon inverter is ideally suited for all general industrial applications requiring accurate control
- Variable speed allows accurate process control, improved product quality and throughput, and energy savings.
- Blending/ mixing - better control of product components and their preparation
- Speed follower/adjust- conveyor system control, adjustment of throughput for best result ( baking ovens, bottling, product assembly etc.)
- Pressure/flow control (energy savings) -pump/fan, liquid/ air/gas flow etc.
- Multimotor - equal load sharing in linked conveyor, feed systems etc
- Soft starter - prevent damage and upset process from DOL starters of conveyors, feed systems etc.

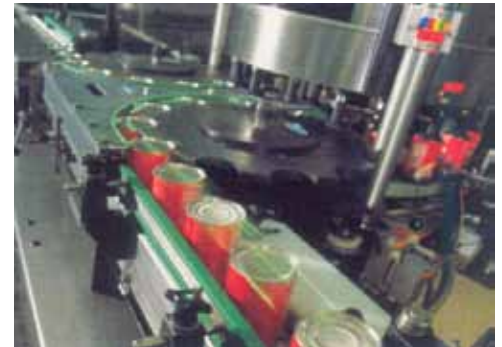

### Optimum control in heavy machineries applications requiring precise control of torque and speed

- Cranes, elevators, hoists requiring precise motion control and stop/hold capacity
- Paper machines and rolling mills where precise control prevents disruption of sensitive processes.
- Materials handling/indexing where precise delivery and positioning of products is essential.



### Optimum control in pump and fan applications

- Energy savings of up to 50% are achievable by matching pump/fan speed to process requirements
- Stepless speed control eliminates stop/start and throttling/ damper induced problems in pumps & fans
- Variable speed prevents water hammer surge and increase pump life.



## Instructions on nameplate

ADEX-AEL ADECON-INVERTER	
AC Motor Drivers Model	Type AI-9200 0022M3
Rated kW	Power 22 kW
Input Spec.	Input AC 3PH 380~460V 50/60Hz
Output Spec.	Output AC 3PH 380~460V 45A 0~800Hz
Product identification Code	 704699010220150022 Made in Bangladesh by Adex Engineering Ltd.

### Model designation:

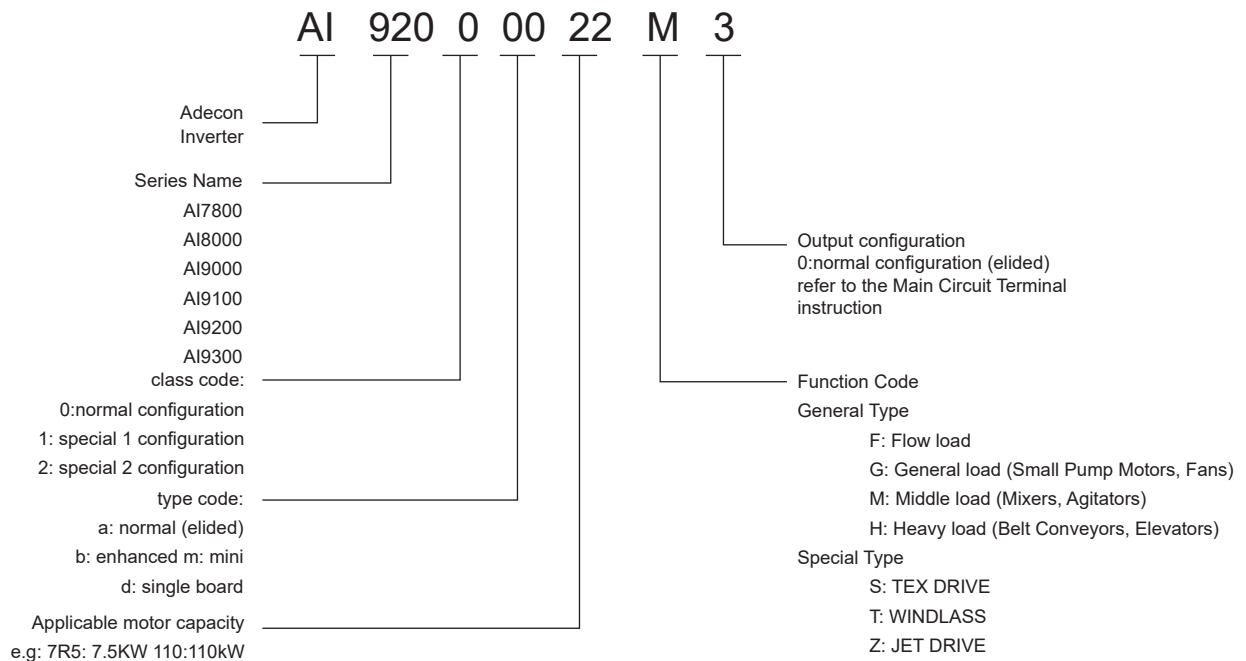

## Optimum control & other applications



- p **Steel:** converter trending lance lifting, crystal concussion, roll gang of cold machine automatically charging of electric arc stove, continuous casting...
- p **Port:** bucket coal whipper, shock absorption for oil dock screw pump, bridge lifting device...
- p **Municipal administration:** Boiler system, central air conditioner system, sewage disposal water supply and drainage engineering...
- p **Coal mine:** Main fan blower in the entrance of mine, gas concentration control in mine, heavy medium in coal washer ...
- p **Chemical industry:** Chemical reaction heating calcination furnace, filter separator, first ammonia pump...
- p **Textile:** scale linkage, mucilage glue filature, braiding machine, printing machine
- p **Oil field:** offshore platform oil electric pump, pump jack, oil conveying system
- p **Machine:** food machinery, packing machinery, printing machinery, frequency converter air conditioner, plastic machinery...
- p **Electric power:** boiler mill exhauster, boiler system, coal transportation...
- p **Pharmacy:** fermentation tank control, stirring control correlative blower and bump control...
- p **Building:** cement plant rotary kiln, blade type crusher, plastic screw extruding...
- p **Paper making:** rewinder, calender, pulp pump...



## Motor Soft Starter



### Standard Specification

- Advanced five kinds of startup modes: Voltage slope startup mode; current limiting startup mode; trip and current limiting startup mode; trip and increase voltage startup mode; current slope startup mode; double close loop startup mode.
- Braking mode: voltage slope soft braking and free braking.
- Main circuit is 3 lines input and 6 lines output, which can realize automatic monitoring.
- Programmable delay startup mode, programmable interlocks control and programmable malfunction junction point output.
- The startup and braking time can be revised by program.
- Comprehensive protection functions: over current, over load, over heat and Default Phase of input and output.
- Three relay and one analog output.
- Automatic discerns phase sequence and protection function
- Special compact design.
- High reliability.

### Nameplate specification

 <b>ADEX-AEL ADECON-SOFT STATER</b>	
TYPE:	AC2 017
SOURCE:	3 $\Omega$ 460V 50Hz
OUTPUT:	17KW 38A
 704699210220150017	
Made in Bangladesh by Adex Engineering Ltd.	

### Soft starter model:

**A AC 2 017 - 3 - G**

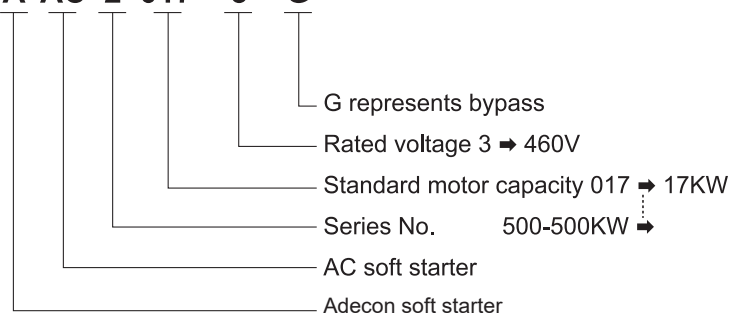

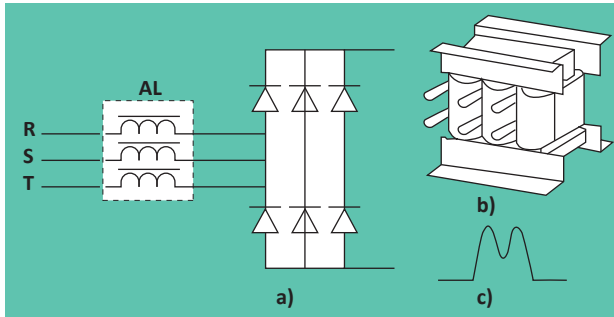

### Adecon Reactor

#### Input AC Reactor

1. Improves input power factor of the inverter.
2. Minimizes input current harmonics.
3. Balances voltage between phases of the power supply and controls surges.

#### Output AC Reactor

The benefit of using output AC Reactor:

1. Reduces output harmonics and the radio wave interference generated by the inverter
2. Minimizes the common mode interference at the output terminal and motor bearing current
3. Output chokes are supplied for reducing the capacitive currents and dV/dt in the case of cables between motor and inverter longer than 30 meters.

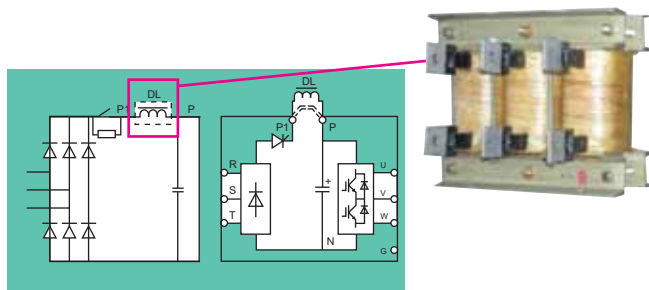

### DC Reactor

1. Improves the input power factor of the inverter.
2. reduces input current crest value and minimizes heat dissipation of the inverter.

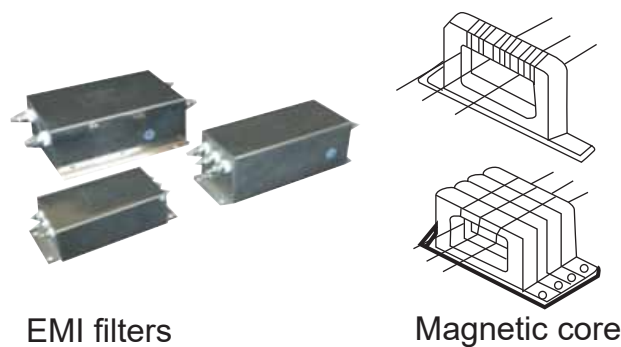

EMI filters

Magnetic core

### Adecon EMI Filter

#### Input EMI Filter

1. EMI filters are used to control the radiation interference generated by a inverter, or the interference generated by external radio interference, transient surge or inrush current.
2. The ferrite chip common mode filter (magnetic core) is used to control the radiation interference generated by the inverter.

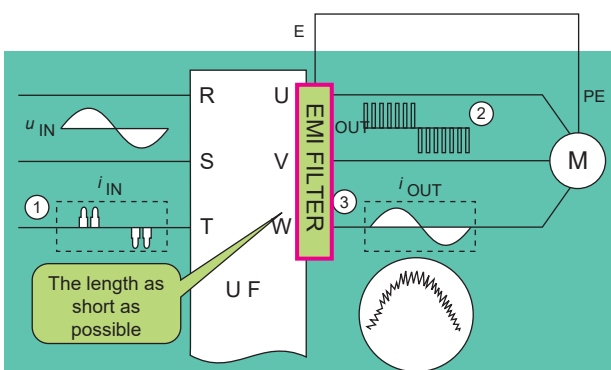

#### Output EMI Filter

1. Controls surge voltage and higher harmonic interference generated by the inverter.
2. Reduces the common mode interference at the output terminal and motor bearing current.

## Installation Dimension

AI 7800 series  
(3-phase 380-460V 50/60Hz)

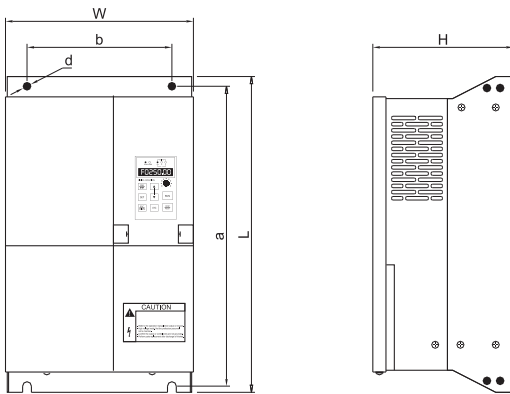

### 1)1N2

Type	(kW)	Structure item	Shape			Installation dimension			Net Weight kg	Gross weight kg	Keypad
			L	W	H	a	b	d			
F	11~18.5	1N2	360	235	207	340	150	∅10	10	11	AC6E7800
G	7.5~15										
M	5.5~11										
H	5.5~11										

### 2)1N3

Type	(kW)	Structure item	Shape			Installation dimension			Net Weight kg	Gross weight kg	Keypad
			L	W	H	a	b	d			
F	22~30	1N3	410	264	242	390	165	∅10	14	15.5	AC6E7800
G	18.5~22										
M	15~18.5										
H	11~15										

### 4) 2N2

Type	(kW)	Structure item	Shape			Installation dimension			Net Weight kg	Gross weight kg	Keypad
			L	W	H	a	b	d			
F	55~93	2N2	660	365	293	640	250	∅10	40	48	AC6E7800
G	45~75										
M	37~55										
H	30~45										

## AI 8000 series

(3-phase 380-460V 50/60Hz)

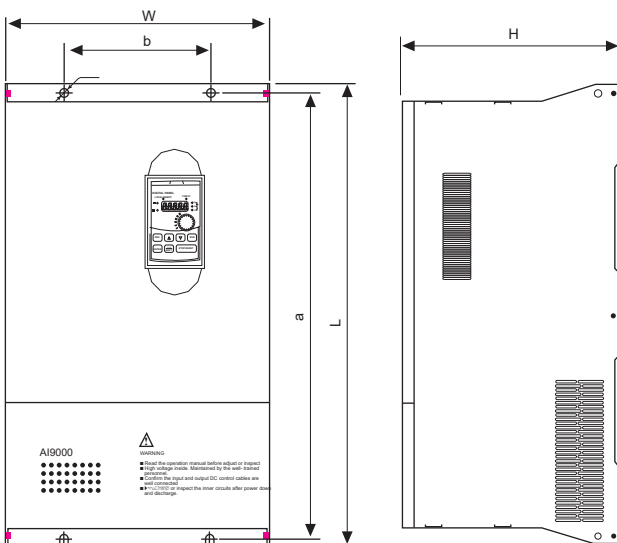

### 8N2

Type	Power (kW)	Structure item	Shape			Installation dimension		
			L	W	H	a	b	d
F	15~18.5	8N2	380	220	230	360	135	∅10
G	11~15							
M	7.5~11							
H	7.5							

### 5) 2N3

Type	(kW)	Structure item	Shape			Installation dimension			Net Weight kg	Gross weight kg	Keypad
			L	W	H	a	b	d			
F	110~132	2N3	710	455	293	690	350	∅10	57	68	AC6E7800
G	93~110										
M	75~93										
H	55~75										

### 6) 2N4

Type	(kW)	Structure item	Shape			Installation dimension			Net Weight kg	Gross weight kg	Keypad
			L	W	H	a	b	d			
F	160~187	2N4	910	480	342	890	350	∅10	72	86	AC6E7800
G	132~160										
M	110~132										
H	93~110										

### 2.3N1

Type	(kW)	Structure item	Shape			Installation dimension			Net Weight kg	Gross weight kg	Keypad
			L	W	H	a	b	d			
F	200~250	3N1	1540	515	443	465	367	∅13	160	190	AC6E7800
G	187~220										
M	160~187										
H	132~160										

### 3.3N2

Type	(kW)	Structure item	Shape			Installation dimension			Net Weight kg	Gross weight kg	Keypad
			L	W	H	a	b	d			
F	280~400	3N2	1700	850	492	640	260	∅13	280	350	AC6E7800
G	250~355										
M	200~280										
H	187~250										

### 3)2N1

Type	(kW)	Structure item	Shape			Installation dimension			Net Weight kg	Gross weight kg	Keypad
			L	W	H	a	b	d			
F	37~45	2N	560	300	243	540	200	∅10	22	23.5	AC6E7800
G	30~37										
M	22~30										
H	18.5~22										

## AI 9000 series

(3-phase 380-460V 50/60Hz)

### 1) 9S2

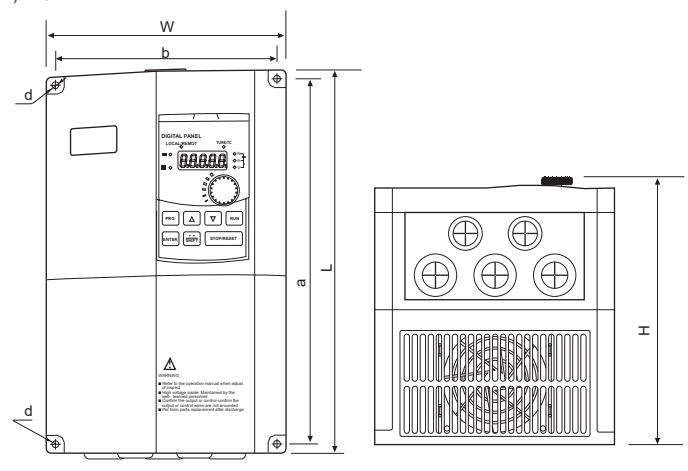

Power supply level	Type	Power (kW)	Dimensions			Installation size		
			L	W	H	a	b	d
3-phase 220V	G	0.4 to 1.5	185	120	178.5	174	108	∅5.3
3-phase 380V	G	0.75 to 2.2						

## Installation Dimension

AI 9000 series  
(3-phase 380-460V 50/60Hz)

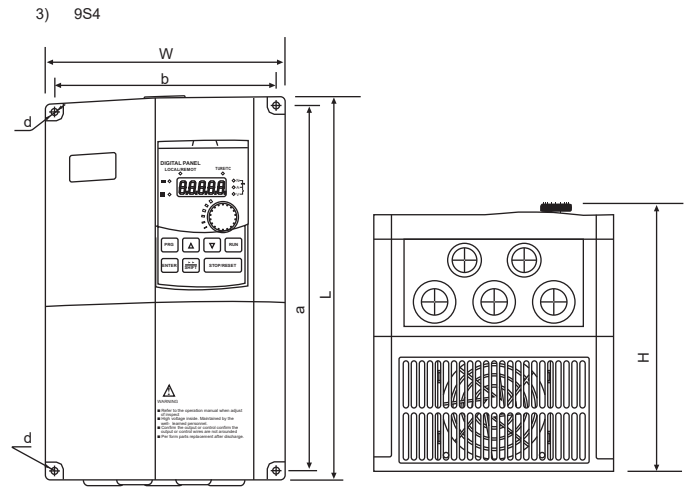
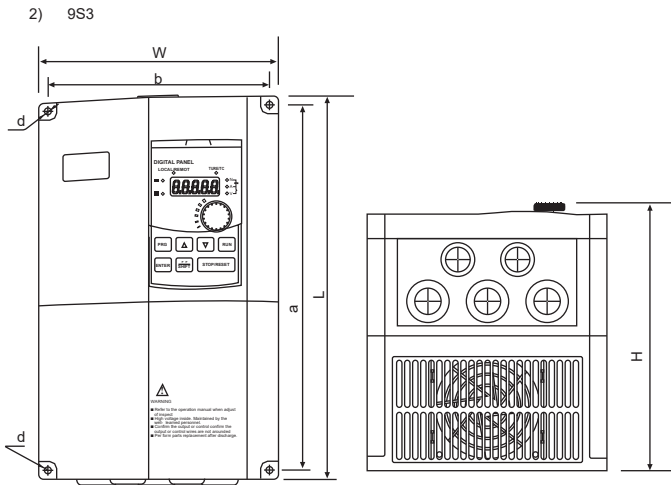

Power supply level	Type	Power (kW)	Dimensions			Installation size		
			L	W	H	a	b	d
3-phase 220V	G	2.2 to 4	220	150	185.5	209	138	Ø5.3
	F	5.5						
3-phase 380V	F	5.5	220	150	185.5	209	138	Ø5.3
	G	4 to 5.5						

Power supply level	Type	Power (kW)	Dimensions			Installation size		
			L	W	H	a	b	d
3-phase 380V	F	7.5	285	180	200	272	167	Ø5.5
	G	7.5						

AI 9200 series  
(3-phase 380-460V 50/60Hz)

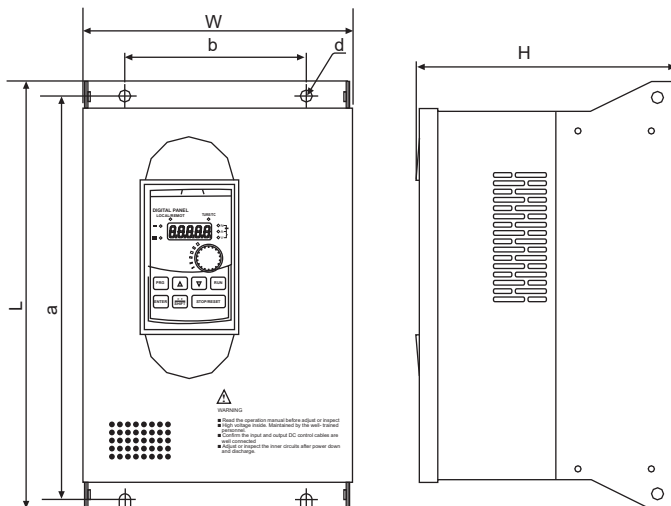

1) 9L1

Power supply level	Type	Power (kW)	Base No.	Dimensions			Installation size		
				L	W	H	a	b	d
3-phase 380V	F	11 to 18.5	9L1	360	220	210	340	150	Ø10
	G	11 to 15							

2) 9L2

Power supply level	Type	Power (kW)	Base No.	Dimensions			Installation size		
				L	W	H	a	b	d
3-phase 380V	F	22 to 30	9L2	435	225	242	415	165	Ø10
	G	18.5 to 22							

3) 9L3

Power supply level	Type	Power (kW)	Base No.	Dimensions			Installation size		
				L	W	H	a	b	d
3-phase 380V	F	37 to 45	9L3	480	296	246	460	200	Ø10
	G	30 to 37							

4) 9L4

Power supply level	Type	Power (kW)	Base No.	Dimensions			Installation size		
				L	W	H	a	b	d
3-phase 380V	F	55 to 90	9L4	660	364	280	640	250	Ø10
	G	45 to 75							

5) 9L5

Power supply level	Type	Power (kW)	Base No.	Dimensions			Installation size		
				L	W	H	a	b	d
3-phase 380V	F	110 to 132	9L5	710	453	280	690	350	Ø10
	G	90 to 110							

6) 9L6

Power supply level	Type	Power (kW)	Base No.	Dimensions			Installation size		
				L	W	H	a	b	d
3-phase 380V	F	160	9L6	910	480	323	890	350	Ø10
	G	132 to 160							

## Installation Dimension

AI-9300 series  
(3-phase 380-460V 50/60Hz)

### 9C1 to 9C3

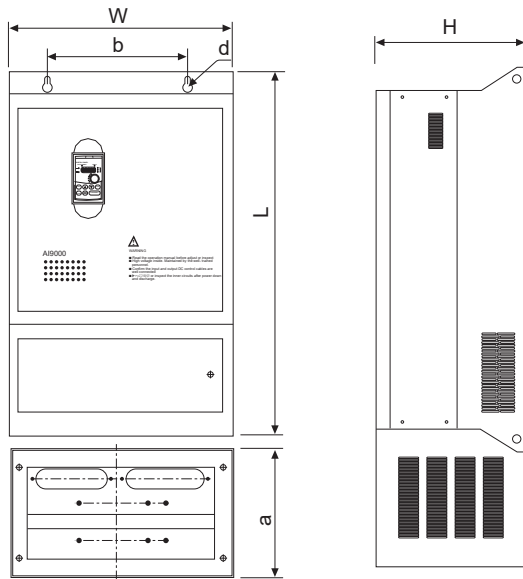

#### 1) 9C1

Power supply level	Type	Power (kW)	Base No.	Dimensions			Installation size		
				L	W	H	a	b	d
3-phase 380V	F	200 to 220	9C1	1300	600	380	550	280	Ø13
	G	200 to 220							

#### 2) 9C2

Power supply level	Type	Power (kW)	Base No.	Dimensions			Installation size		
				L	W	H	a	b	d
3-phase 380V	F	200 to 250	9C2	1540	515	421	464.5	367	Ø13
	G	200 to 220							

#### 3) 9C3

Power supply level	Type	Power (kW)	Base No.	Dimensions			Installation size		
				L	W	H	a	b	d
3-phase 380V	F	280 to 400	9C3	1698	851	470	640	260	Ø13
	G	250 to 355							

AI-9400 series  
(3-phase 380-460V 50/60Hz)  
9P4 to 9P7

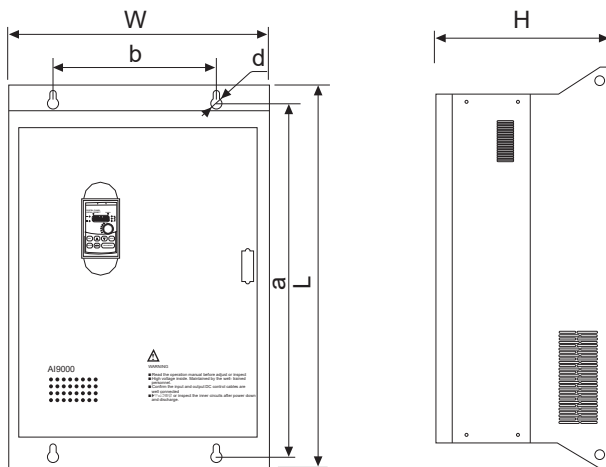

#### 1) 9P4

Power supply level	Type	Power (kW)	Base No.	Dimensions			Installation size		
				L	W	H	a	b	d
3-phase 380V	F	45 to 75	9P4	620	360	300	600	250	Ø10
	G	45 to 55							

#### 2) 9P5

Power supply level	Type	Power (kW)	Base No.	Dimensions			Installation size		
				L	W	H	a	b	d
3-phase 380V	F	90 to 110	9P5	680	323	320	660	250	Ø10
	G	75 to 90							

#### 3) 9P6

Power supply level	Type	Power (kW)	Base No.	Dimensions			Installation size		
				L	W	H	a	b	d
3-phase 380V	F	132 to 160	9P6	750	472	324	730	350	Ø10
	G	110 to 160							

#### 4) 9P7

Power supply level	Type	Power (kW)	Base No.	Dimensions			Installation size		
				L	W	H	a	b	d
3-phase 380V	F	200 to 220	9P7	1000	600	383	938	370	Ø14
	G	200 to 220							

## ADEX ENGINEERING LTD.

### Corporate Office:

374 Tejgaon I/A (4<sup>th</sup> & 5<sup>th</sup> Floor)  
Dhaka-1208, Bangladesh.  
Tel: +88-02 - 55029737, 55029738  
E-mail: info@adexbd.com

### Chattogram Office:

bti Kanchan, Flat - A2, House - 25  
Road - 2, O.R Nizam Road R/A  
GEC Circle, Chattogram – 4000  
Phone: +88 01713 436281  
E-mail: adex\_ctg@adexbd.com

### Sylhet Office:

Natun Bridge, Shayestagonj  
Station Road, Hobigonj  
Mobile: +88 01708 499990  
E-mail: adex\_sylhet@adexbd.com

### Khulna Office:

Mirza Cottage  
119 Sonadanga Thana Road  
Mojid Saroni, Sonadanga, Khulna  
Mobile: +88 01709 632890  
E-mail: adex\_khulna@adexbd.com

### Bogura Office:

Rimu & Tanvir Monjil (1<sup>st</sup> Floor)  
House - 2, Road - 1, Masjid Line  
Upashahor Bazar, Bogura  
Mobile: +88 01729 212188  
E-mail: adex\_bogura@adexbd.com

### Cumilla Office:

32/ka Tri-Ratno (3<sup>rd</sup> Floor)  
Islampur, Fousdari Chowmohoni  
Judge Court Road, Cumilla  
Mobile: +88 01708 499990  
E-mail: adex\_comilla@adexbd.com

### Factory:

Unit-1: Holding No. 3060/3798  
West Dogri, Bhawal Mirzapur  
Unit-2: J.L No. 6, Mouja: Dogri  
Union: Mirzapur, Gazipur, Bangladesh  
E-mail: ael\_works@adexbd.com

