

Adex ACB : NIRAPOD 4

Low Voltage Air Circuit Breaker

800A-6300A, 1000V

40kA-125kA



an innovative user friendly circuit breaker

with microprocessor control unit for protection and measurements as standard suitable for all applications in:

- > Industry
- > Infrastructures
- > Constructions
- > Utility

NIRAPOD 4 Air Circuit Breaker

Presentation

NIRAPOD 4 air circuit breakers are designed and made incorporating universal control unit NIRAPOD4.02M/H having protection, control & measurement functions. They may be installed in main LV switchboards as incoming units, main and secondary outgoing. NIRAPOD 4 acb offers a complete range with a large selection of performance level:

- ratings from 800 to 6300 A AC,
- breaking capacity from 40 to 100 kA rms;
- operational voltages 690V AC 1000V DC

NIRAPOD-4 circuit breakers are equipped with microprocessor - based electronic control units. All the protection functions are powered by the AC system and no auxiliary power supply is required. The same is true for most of the complementary functions.

NIRAPOD4.02M/H control units measure the true rms value of the current Voltages $\cos\phi$, Hz, kW, reading and are therefore not affected by harmonics that may be present on the system.

NIRAPOD 4 circuit breakers comply with all the major international standards:

- International standard IEC 60947-2 They also comply with the following national standards:
- Germany VDE 0660
- United Kingdom BS 4752
- Italy CEI

Adex circuit breakers comply with the specifications of the marine classification companies

Tropicalisation

As standard, NIRAPOD 4 circuit breakers are designed for tropical conditions with 95% relative humidity at 45°C or 80% at 55°C, hot and humid climate conditions. They also comply with the following standards:

- IEC 68-2-30 damp heat
- IEC 68-2-2 dry heat
- IEC 68-2-11 salt spray
- IEC 68-2-1 low temperatures during storage.

Corrosive atmospheres: Special grease or other surface coatings available (please consult us).



Operating safety

The insulating casing of NIRAPOD 4 circuit breakers provides for:

- user safety:
 - double insulation on the front face (class II)
 - auxiliary circuits in a compartment insulated from the power circuits
- switchboard safety when the circuit breaker is in the open position
 - each pole is effectively isolated in its own housing
 - limitation of external disturbances

Positive contact indication

The position indicator cannot indicate "open" unless the poles are effectively separated by the required distance.

The circuit breakers automatically open during racking in and out.

reliability

- NIRAPOD 4 circuit breakers comprise ten times fewer parts than traditional devices. They are easier to produce and more reliable.
- the design of Adex circuit breakers is modular with delayed differentiation (highest possible number of common parts on all models). The result is shorter delivery times and enhanced reliability.

NIRAPOD 4 Air Circuit Breaker

Ease of installation

NIRAPOD-4 is a complete and rationally designed range.

- 10 ratings;
- wide breaking-capacity levels;
- 1 control units covers all the protection & measurement functions
- a complete range of auxiliaries and accessories;
- numerous versions (three and four-pole devices, fixed and drawout versions, etc.).

NIRAPOD-4 circuit breakers are easy to incorporate in switchboards

- a single frame size from 800 to 6300 A, thus making for standardised columns;
- an upper safety clearance equal to zero due to the arc-chute cover, on both the fixed and drawout versions;
- built-in measurement functions in the control units;
- auxiliaries are the same for the entire range and may be easily implemented (only a screwdriver is required).

NIRAPOD-4 circuit breakers are easy to connect to the main distribution system.

- all types of connections are available (horizontal and vertical terminals, front and mixed connections);
- connections are possible with bars of any thickness
- connection to the input power source is possible on the upper or lower terminals of the circuit breakers.

Due to their small size, NIRAPOD 4 circuit breakers can replace most existing circuit breakers.

Maximum dependability

All NIRAPOD-4 circuit breakers are also disconnectors (suitable for isolation) as specified by IEC 60947-2. They bear the corresponding symbol on the front cover:

This characteristic considerably increases the dependability of the circuit breaker.

The conditions specified by IEC 60947-2 for this function are:

- positive contact indication;
- impulse withstand; 8kV at sea level;
- very low leakage current, checked on new circuit breakers and on circuit breakers subjected to tests representative of the end of service life.

Moreover Adex circuit breakers have a double- insulation front face (i.e.a class II device) allowing control from the outside.

Installation

NIRAPOD 4 circuit breakers may be installed on horizontal metal surfaces or on rails. They are secured by four points accessible at the bottom of the chassis (drawout versions) or on either side of the circuit breaker (fixed versions.) A single door cut-out is required for the entire range and provides access to NIRAPOD 4 controls.

Standards

IEC 60947-2

This standard provides the user with a better guarantee concerning quality and performance.

Circuit breakers are subjected to tests that are more representative of real operating conditions.

Definition of the terms breaking capacity:

IEC 60947-2 also clarifies the notion of breaking capacity.

- **Icu**: the ultimate breaking capacity, which must be greater than or equal to the 3-phase short-circuit current at the point of installation of the circuit breaker, a value unlikely to be reached under real conditions;
- **Ics**: the service breaking capacity, generally expressed as a percentage of the ultimate breaking capacity (25,50,75 or 100% of Icu). It corresponds to a short-circuit current that is more likely to be reached under real conditions. The circuit breaker must continue to operate normally after having interrupted a current equal to Ics several times;
- **Icw**: short-time withstand current for circuit breakers belonging to category B (category B refers to circuit breakers with time discrimination and category A to those without time discrimination).

Furthermore, IEC 60947-2 takes into account recent technological advances:

- suitability for isolation recognised for circuit breakers having passed special electrical and mechanical test;
- industrial earth-fault circuit breakers covered by an appendix;
- definition of tests designed to ensure coordination between two circuit breakers.

NIRAPOD 4

Air Circuit Breaker

Model		NIRAPOD 4							
control unit		NIRAPOD 4.02M/H							
Basic protection									
Long time protection LT									
adjustable current setting (I _r) in 2% steps		I _r = I _n x ...		0.4 to 1					
tripping range		between 1.05 and 1.20 x I _r							
time delay (tr)		adjustable							
accuracy :+0 -20%		tr at 1.5 I _r (s)		15	30	60	120	240	480
		tr at 6 I _r (s)		0.94	1.88	3.75	7.50	15	30
		tr at 7.2 I _r (s)		0.65	1.30	2.60	5.20	10	21
Short time protection ST									
adjustable pick-up (I _m) in 4% steps		I _m = I _r x ...		0.4 to 15 ± 10%					
time delay (tr)		tm setting with I ² t OFF		0.09	0.18	0.27	0.36		
		tm setting with I ² t ON		0.09	0.18	0.27	0.36		
		max. overcurrent time before tripping (ms)		60.9	140.9	230.9	350.9		
		max. break time (ms)		140.9	230.9	350.9	500.9		
Instantaneous protection I									
fixed pick-up I (kA)		see technical data page							
pick-up (I) adjustable in 8% steps		from I _n to fixed pick-up (mini at 1.6 kA)							
accuracy		± 15%							
OFF switch on front face		on types N1 and H1							
Basic functions									
Fault indication									
for tripping on a fault		button on front face		■					
		fault trip alarm contact		■					
for I _r setting overrun		LED on front face		■					
		self powered		■					
indication of fault type		LEDs on front face		■					
and value of interrupted current		display on ammeter		■					
Self-monitoring		internal overheating and microprocessor errors		■					
self-powered		■							
Integrated test		■							

Electrical operating mechanism

Added to the manual charging mechanism, a motor charges and automatically recharges the stored-energy spring upon breaker closing making possible fast O-C-O cycles. Opening and closing operations are instantaneous. The manual mechanism remains available for emergency use.

The electrical operating mechanism includes:

- the gear motor
 - a closing release
 - a shunt release or an undervoltage release for opening;
 - "springs charged" limit switch changeover contact
- The addition of the electrical operating mechanism does not alter circuit breaker dimensions.

characteristics	geared motor	
power supply	50/60 Hz (V)	100/127 - 200/240 - 250/277 - 380 - 415 - 440 - 480
	consumption (VA)	180
	DC (V)	24/30 - 48/60 - 100/125 - 200/250
	consumption (W)	180
motor start-up surge	2 to 3 I _n for 0.1 s	
charging time	3 to 4 s	

NIRAPOD 4 Air Circuit Breaker

Protection & measurement

The NIRAPOD 4.02M/H control unit is used as standard for protection, measurement and supervision functions. The liquid crystal display and function keys ensure high accuracy and easy adjustment. The standard NIRAPOD 4.02M/H control unit provides the following:

- universal protection for overcurrent, short circuit & earth faults with different level & adjustable characteristics
- measurement with digital display I, V, kW, $\cos\phi$, Hz, kA, t
- setting & measurement with digital display I, kA, t
- indication of fault type
- values of interrupted currents
- integrated on-load test, trip/no trip conditions.

The NIRAPOD 4.02M/H control unit provides:

- **overload protection**, with long time Protection LT including:
 - adjustable time delay and thermal memory possibility
- **short-circuit protection**:
 - delayed, with short time function ST, for which the I^2t curve can be disabled by the user,
 - instantaneous, with the INST function that can be disabled by the user
- **"earth" protection** with time discrimination or zone selective interlocking. The protection is of the residual current type (or source ground return type on request).

Basic functions: long time LT, short time ST, instantaneous INST

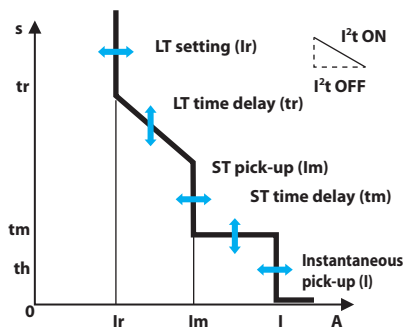

overcurrent settings

- 1 : LT setting I_r (long time)
- 2 : LT time delay t_r (long time)
- 3 : ST pick-up I_m (short time)
- 4 : ST time delay t_m (short time)
- 5 : INST pick-up I (instantaneous)

Earth fault protection (option T)

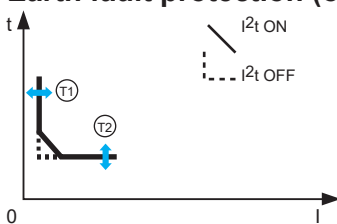

earth fault protection settings

- T1 : earth fault pick-up I_h
- T2 : earth fault time delay t_h

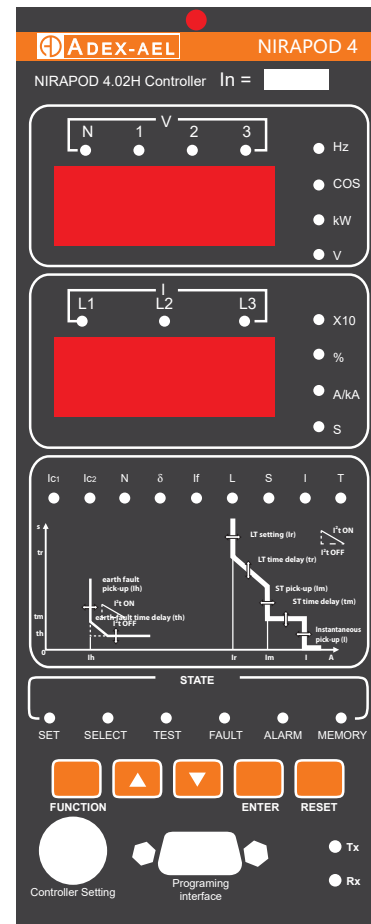

Indication and measurement

a digital display continuously indicates the current of the phase with the greatest load (I_{max}), Voltages, $\cos\phi$, Hz, kW, reading. By pressing a scroll button, it is also possible to display successively the readings of I^1 , I^2 , I^3 & voltage in phases. The display unit also helps setting parameters related to protections & measurement of the programmable control unit.

Factory adjustments

The NIRAPOD 4.02M/H control unit is factory adjusted as follows:

LT	setting I_r	I_n
	time delay t_r	480 s
ST	pick-up I_m	4 I_n
	time delay t_m	0,2 s
INST	pick-up I	maxi
T	earth fault pick-up I_h	0.2 I_n
	time delay t_h	0,1 s
	load monitor	I_{c1} I_n
		I_{c2} I_n

Earth fault protection

This earth fault protection is designed to protect the installation against the risks of fire due to high earth faults (not to be confused with schemes designed for the protection of persons against electrical shock).

Two types of earth protection are available:

- residual current type (T): the control unit calculates the vector sum of the phase and neutral (if distributed) currents
- source ground return type (W): the control unit acts directly on the signal received from an external current transformer installed on the source earthing circuit.

NIRAPOD 4 Air Circuit Breaker

Communication Network: Nirapod 4.02H Controller

Through Modbus-Rtu, Profibus-DP or Device-Net.

The RS485 connection, address and baud rate can be set through the programmer.

The “four remote” function, remote measuring, remote communication, remote control, and remote modifying can be realized through the communication interface.

ST-DP is the communication module. The master station card is SIEMENS's CP5X11, RT is the resistance of the network terminal, usually 150 ohm.

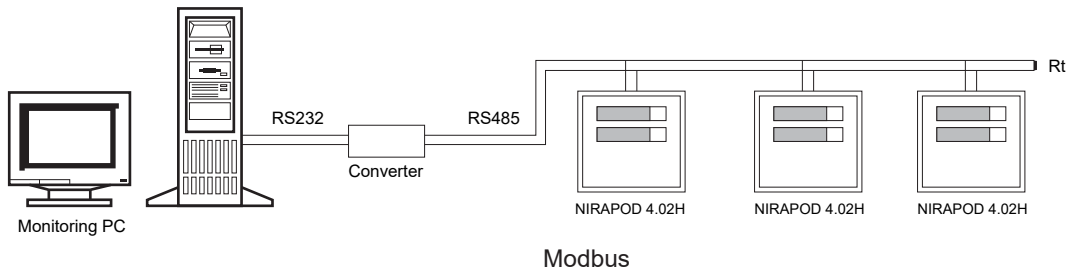

Communication Module

To be used with the H type controller for converting from Modbus-Rtu to Profibus -DP. Auxiliary power is AC/DC 220V
Dimension diagram :



Communication Interface T04

To be used in switchboard for communication connection with the breaker.

(Encoded as 2 in the Switchboard diagram)



Communication Line

For the connection with various communication terminals, A shielding twisted-pair is OK for this purpose. When ST-DP is used, T215-01 is needed; when ST-DN is used, T415-01 is used.



NIRAPOD 4 Air Circuit Breaker

Circuit breakers model				AB08			AB10			
number of poles				3-4			3-4			
Electrical characteristics as per IEC 947-2 and EN 60947-2										
rated current (A)	In	40°C		800			1000			
rating of 4th pole (A)				800			1000			
rated insulation voltage (V)	Ui			1000			1000			
rated impulse withstand voltage (V)	Uimp			8000			8000			
rated operational voltage (V)	Ue	AC 50/60 Hz		690			690			
Type of circuit breaker				N1	H1	H2	N1	H1	H2	
ultimate breaking capacity (1) (kA rms)	Icu	AC 50/60 Hz	220/415 V	40	65	100	40	65	100	
			500/690 V	40	65	85	40	65	85	
service breaking capacity	Ics	(% Icu)		100%	100%	100%	100%	100%	100%	
short - time withstand current (kA rms)	Icw	AC 50/60 Hz	0.5 s	40	65	65	40	65	65	
			1 s	30	50	50	30	50	50	
			3 s	22	32	32	22	32	32	
making capacity (kA peak)	Icm	AC 50/60 Hz	220/415 V	84	143	220	84	143	220	
			440 V	84	143	220	84	143	220	
			500/690 V	84	143	187	84	143	187	
electrodynamic withstand (kA peak)				84	143	143	84	143	143	
utilization category				B			B			
suitability for isolation				■			■			
break time				25 to 35 ms						
closing time				70 ms						
endurance (C-O cycles) x 1000	mechanical	with maintenance		20	20	20	20	20	20	
		no maintenance		10	10	10	10	10	10	
	electrical	no maintenance		440 V - In	10	10	10	10	10	10
				690 V - In	10	10	10	10	10	10
	motor control (AC3-947-4) (2)				690 V	10	10	10	10	10
Installation and connections										
connection				front and rear connections						
version	drawout			■			■			
	fixed			■			■			
Indication and measurement auxiliaries										
auxiliary switches				■			■			
electronic trip unit related functions				■			■			
Control auxiliaries										
auxiliary releases				■			■			
motor mechanism				■			■			
operation counter				■			■			
Installation and connection accessories										
interphase barriers				■			■			
terminal - block cover				■			■			
door frame				■			■			
Dimensions and weights										
dimensions W x H x D (mm)	drawout	3P		290x400x312			290x400x312			
		4P		550x439x367			550x439x367			
	fixed	3P		290x400x312			290x400x312			
		4P		537x356x290			537x356x290			

NIRAPOD 4

Air Circuit Breaker

Drawout wiring diagrams

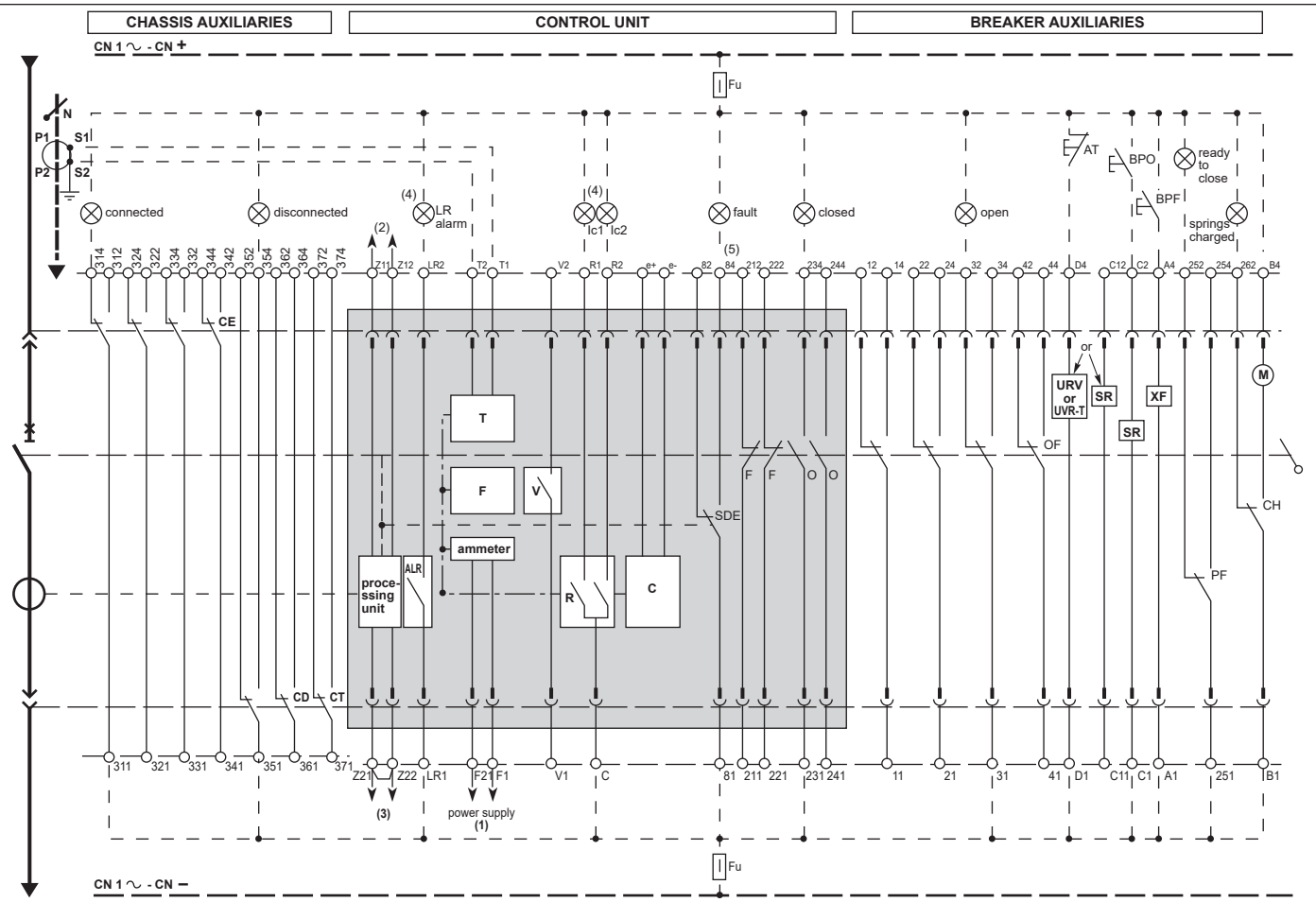

- AT : emergency off
- BPO : "open" push button
- BPF : "close" push button
- LR : long time trip (LT) indicating lamp
- CR : short time trip (ST) indicating lamp
- T : earth fault trip indicating lamp
- CE : "connected" position contact (10A/240V AC)
- M : spring charging motor (180V A/240V AC)
- R : load monitoring and control
- XF : closing release (20V A/240V AC)
- T : earth fault protection (EZ and SZ: input and output for zone selective interlocking)
- SR : shunt release (20V A/ 240V AC)
- UVR : undervoltage release (20V A/240V AC)
- UVR-T: time delayed undervoltage release (20V A/240V AC)
- OF : auxiliary changeover contacts (10A/240V AC)
- O : 2 auxiliary NC contacts (10A/ 240V AC)
- F : 2 auxiliary NC contacts (10A/ 240V AC)
- FTIC : fault trip indication contact (10A/ 240V AC)
- CMS: charging motor limit switch contact
- F : fault trip local indicator
- FV : segregated fault trip indication contact (5A/ 240V AC)
- PF : "ready to close" contact (10A/ 240V AC) (closing possible if breaker is open, not locked and operating mechanism charged)

- CD : "disconnected" position contact (10A/ 240V AC)
- CT : test position contact (10A/ 240V AC)
- C : communication.
- Ic1: load shedding command according to Ic1 setting
- Ic2: load shedding command according to Ic2 setting
- diagram shown with circuits deenergised, breaker open and in "connected" position, springs charged and relays in released position
- accessories such as pushbuttons, lamps and fuses are not supplied with the circuit breaker.

- (1) Power supply terminals for I or T or F options (AD module with BAT battery module for backup power).
- (2) Zone selective interlocking with line side breaker.
- (3) Zone selective interlocking with load side breaker (remove jumper)
- (4) DC power supply R contacts reset request wiring of an external contact
- (5) With Z and/ or C options, terminal 84 is not available.

Wiring of the UVR-T (modified diagram). Instantaneous tripping with UVR-T when contact 254-262 opens.

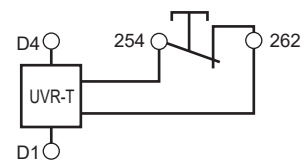

Note: the wiring of the external contact replaces the spring charged indication and the contact PF.

V contact wiring: for breaker locking, depending on the selected fault.

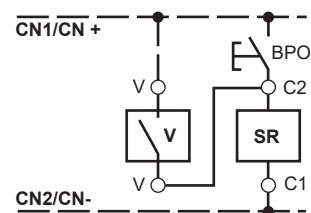

Selective locking needs:
 * external power supply (F1, F2)
 * an additional terminal (BS)

NIRAPOD 4
Air Circuit Breaker

Wiring Diagrams: NIRAPOD 4.02M

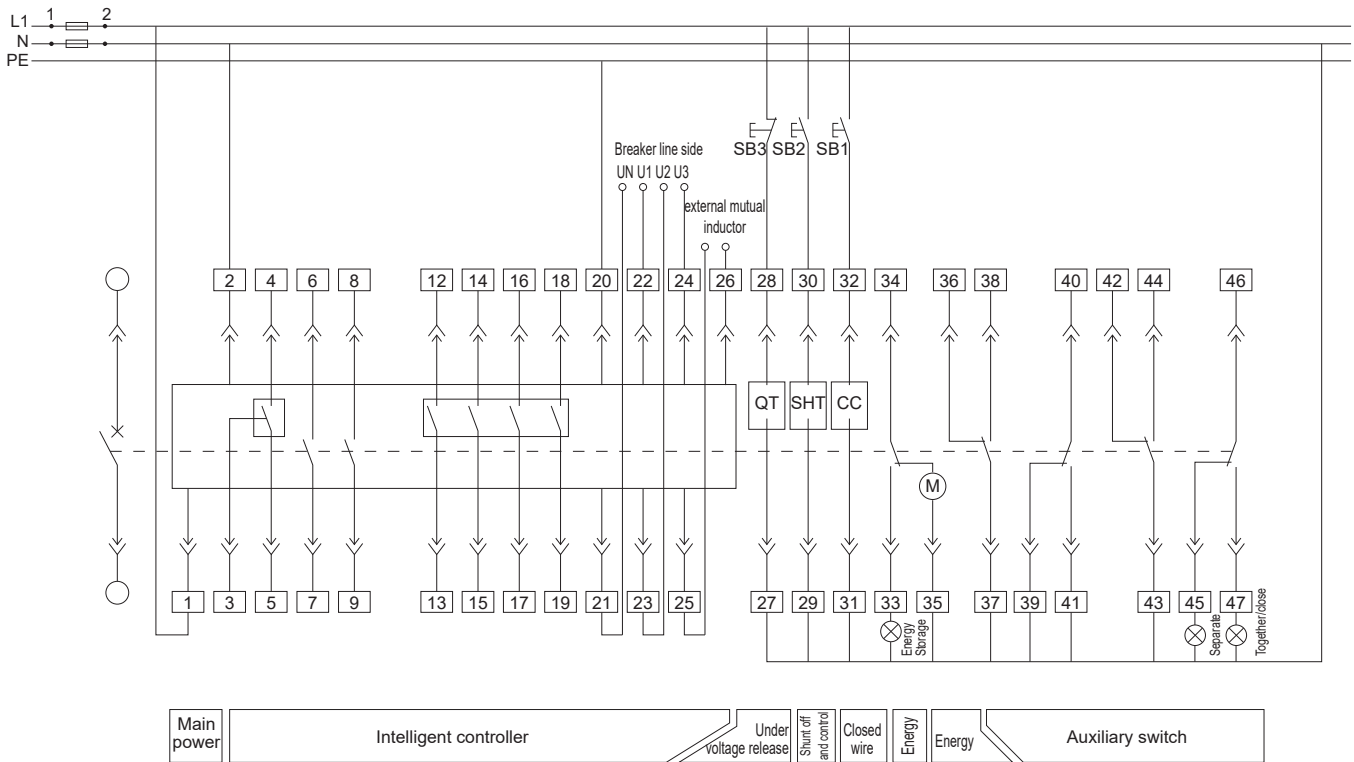

External terminals of NIRAPOD 4.02M

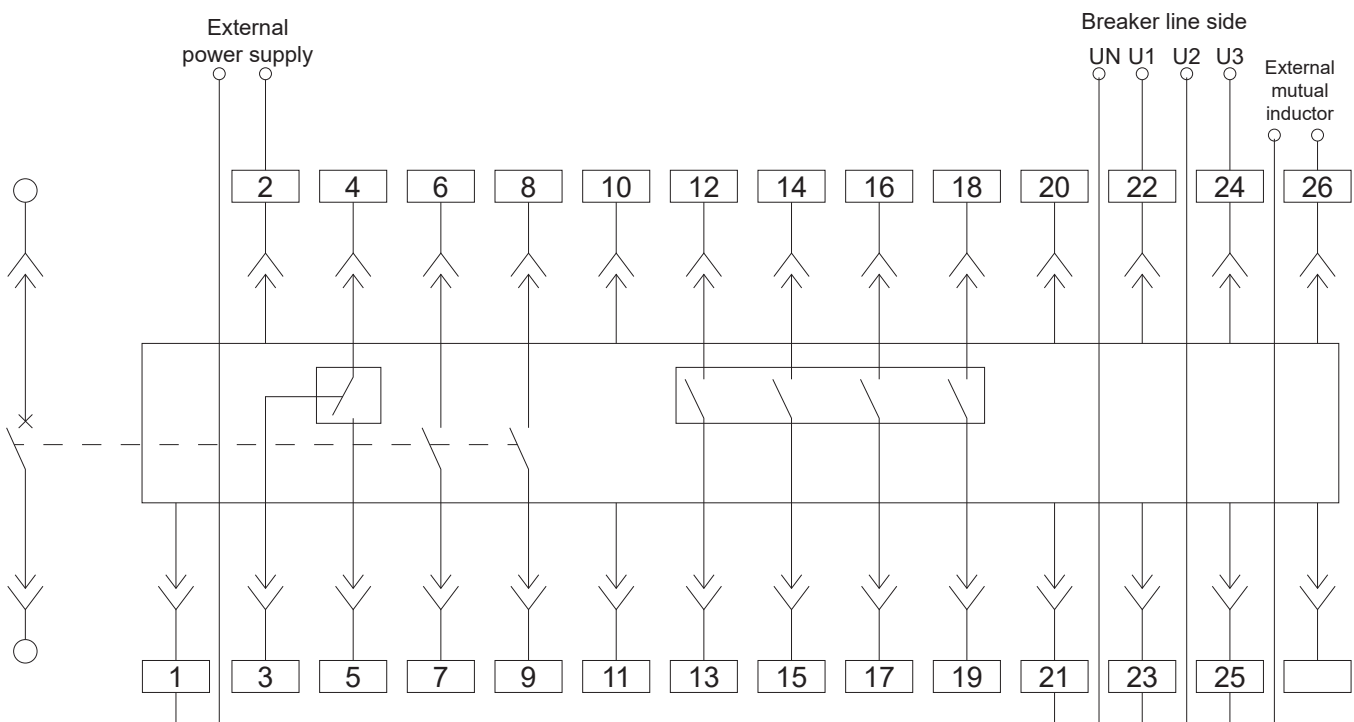

NIRAPOD 4

Air Circuit Breaker

Wiring Diagrams: NIRAPOD 4.02H

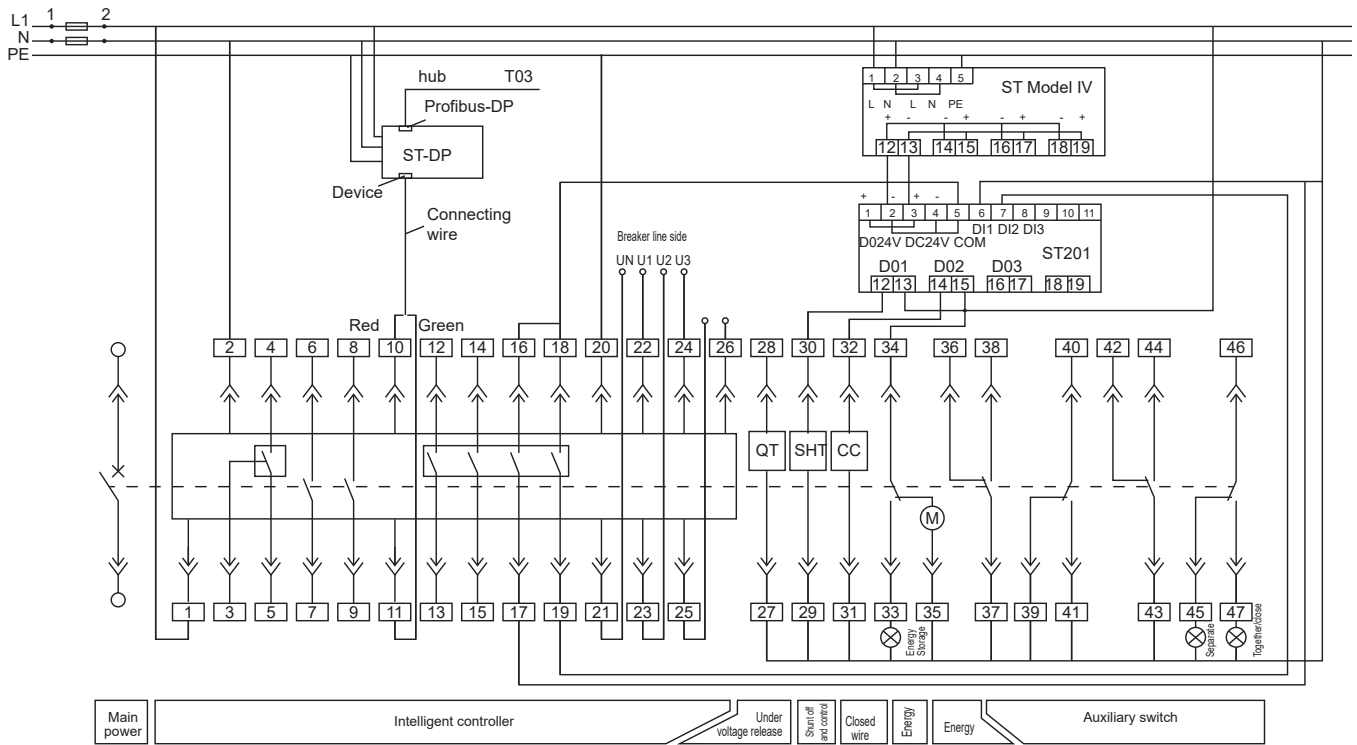

External terminals of NIRAPOD 4.02H

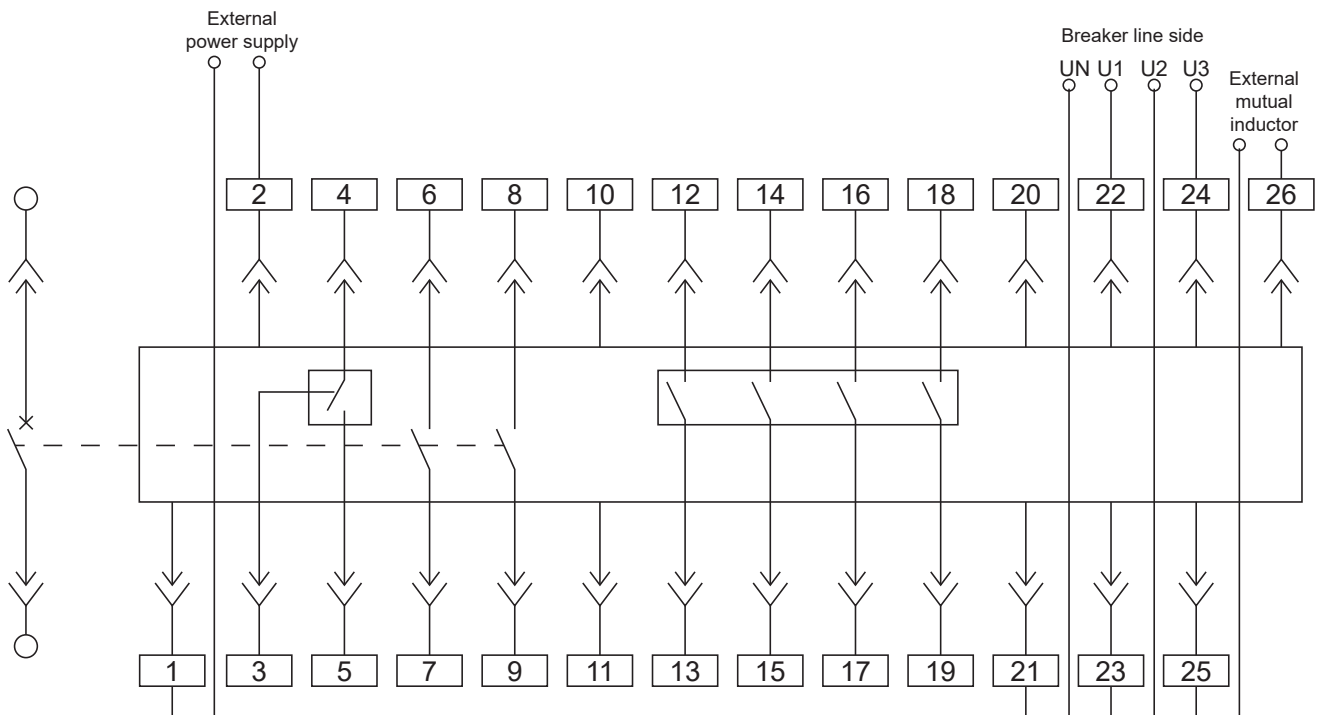

NIRAPOD 4

Air Circuit Breaker

Installation: Fixed circuit breakers AB08 to AB32

Dimensions

3 or 4 poles

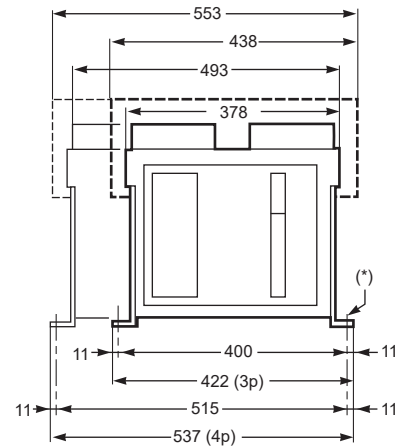
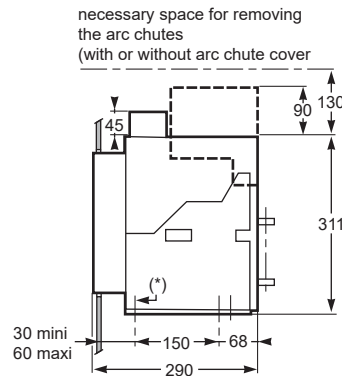
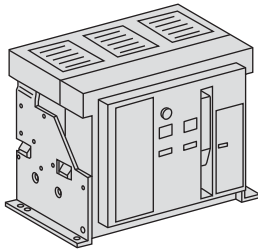

Mounting

on a base plate

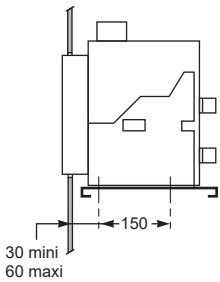

mounting detail

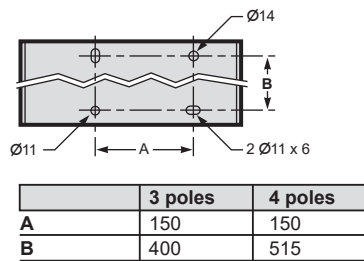

Panel cut-outs

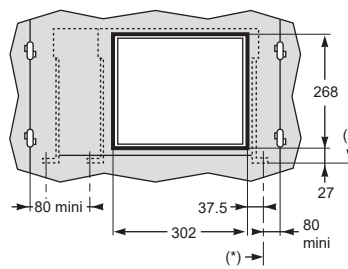

holes for escutcheon

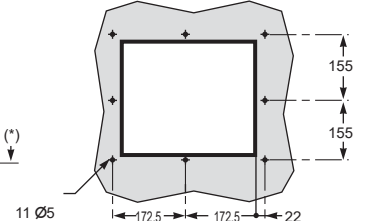

Drawout circuit breakers AB08 to AB32

Dimensions

3 or 4 poles

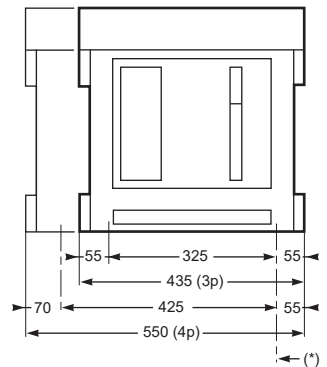
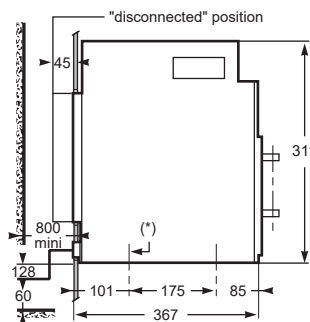
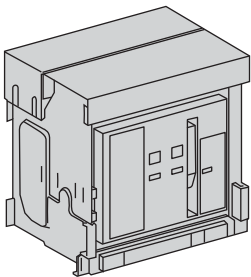

Mounting

on a base plate

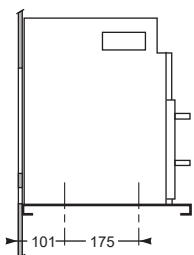

mounting detail

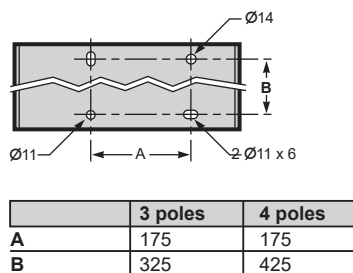

Panel cut-outs

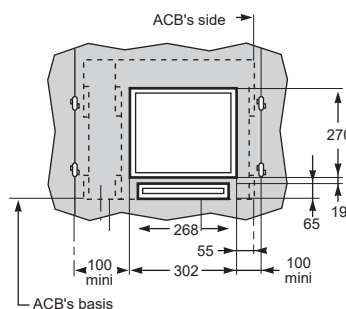

holes for escutcheon

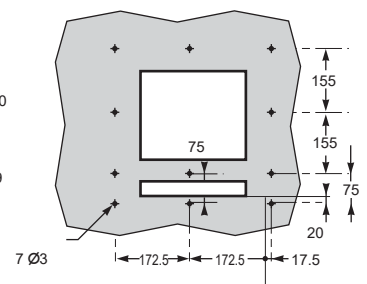

NIRAPOD 4

Air Circuit Breaker

Installation: Fixed circuit breaker AB40

Dimensions

3 or 4 poles

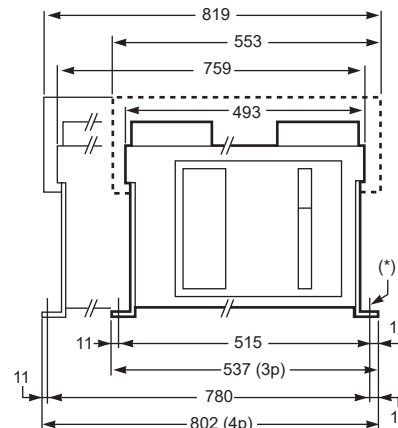
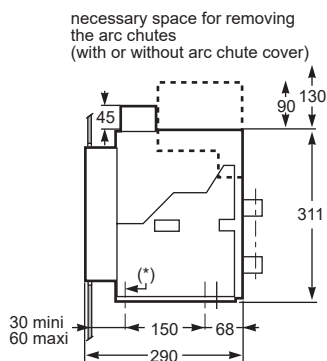
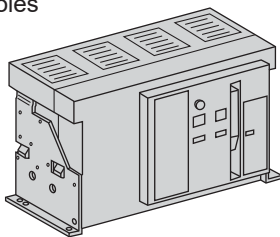

Mounting

on a base plate

mounting detail

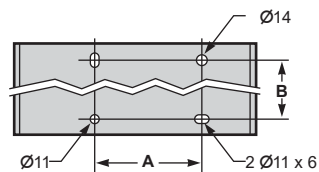
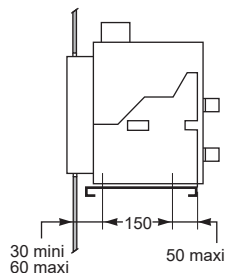

A	150	150
B	515	780

Panel cut-outs

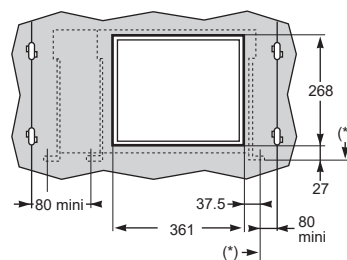

holes for escutcheon

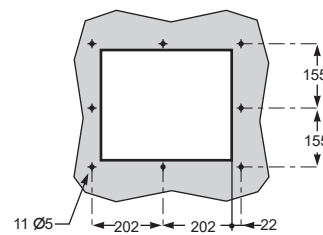

Drawout circuit breaker AB40

Dimensions

3 or 4 poles

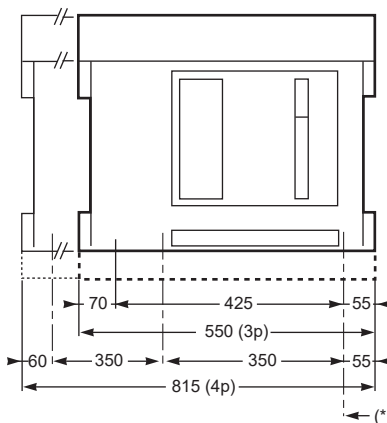
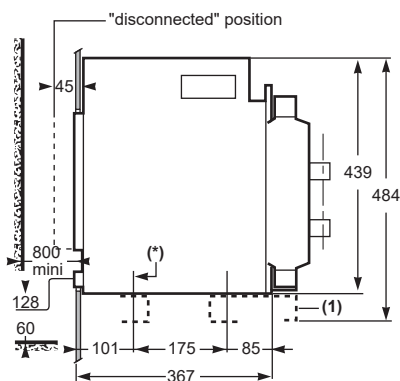
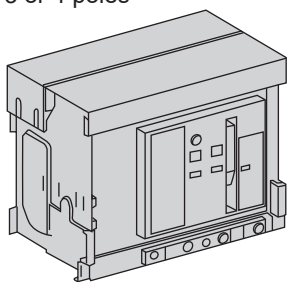

Mounting

on a base plate

mounting detail

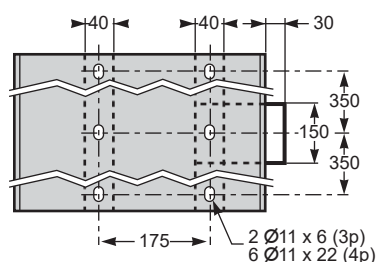
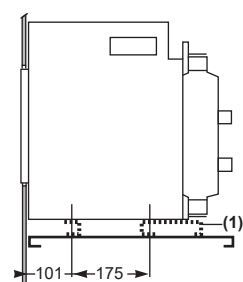

Panel cut-outs

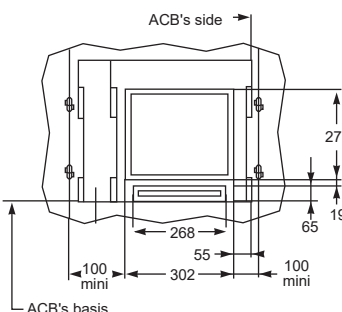

holes for escutcheon

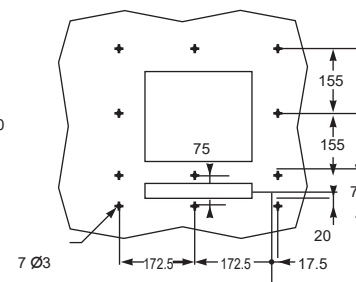

NIRAPOD 4 Air Circuit Breaker

Installation Fixed circuit breaker AB50-63

Dimension

3 poles

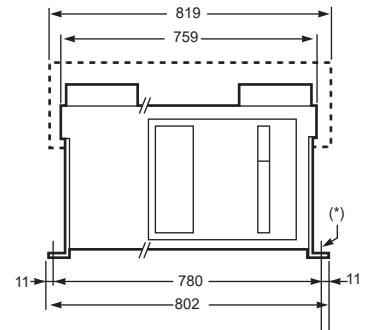
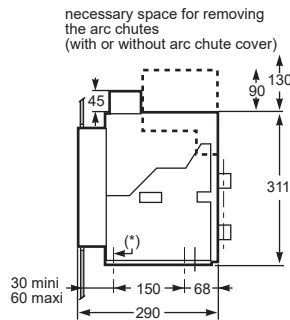
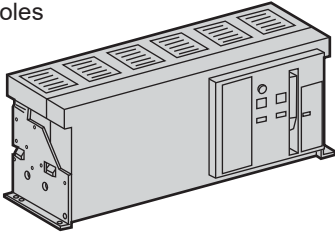

Mounting

on a base plate

mounting detail

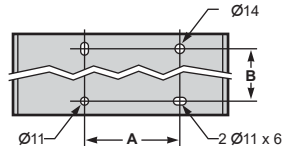
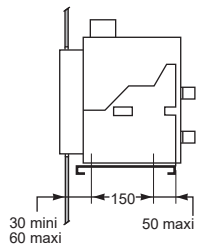

	3 poles
A	150
B	780

Panel cut-outs

holes for escutcheon

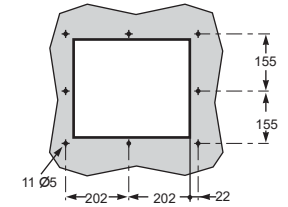
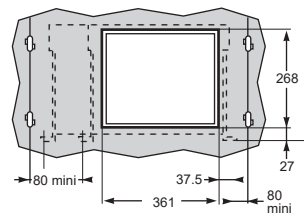

Drawout circuit breaker AB50-63

Dimensions

3 or 4 poles

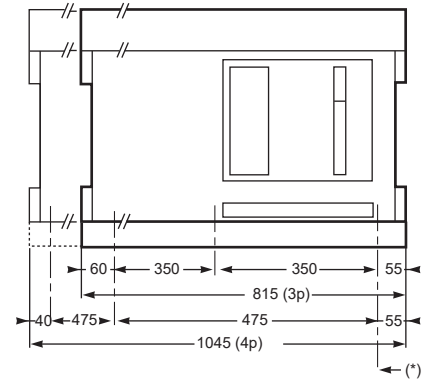
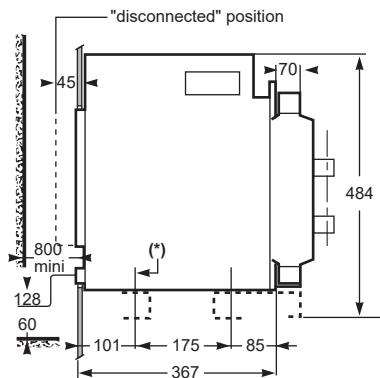
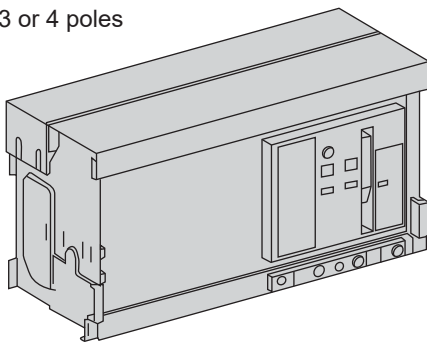

Mounting

on a base plate

mounting detail

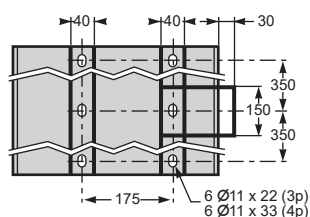
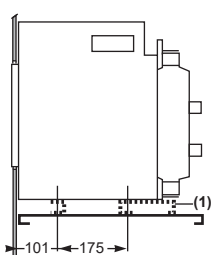

Panel cut-outs

panel cut-outs

holes for escutcheon

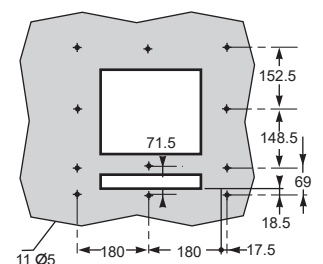
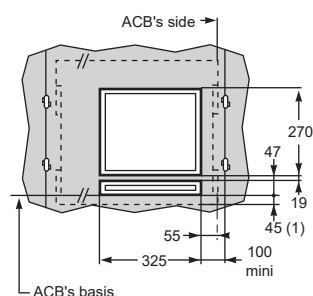

Bitoron-600

Compartmented LV Switchgear
incorporating NIRAPOD 4 circuit breakers
made in conformity to IEC61439-2



a complete low voltage

fully Design Verified assemblies for

- industry
- infrastructures
- construction
- utilities

ADEX ENGINEERING LTD.

Corporate Office:

374 Tejgaon I/A (4th & 5th Floor)
Dhaka-1208, Bangladesh.
Tel: +88-02 - 55029737, 55029738
E-mail: info@adexbd.com

Chattogram Office:

bti Kanchan, Flat - A2, House - 25
Road - 2, O.R Nizam Road R/A
GEC Circle, Chattogram – 4000
Phone: +88 01713 436281
E-mail: adex_ctg@adexbd.com

Sylhet Office:

Natun Bridge, Shayestagonj
Station Road, Hobigonj
Mobile: +88 01708 499990
E-mail: adex_sylhet@adexbd.com

Khulna Office:

Mirza Cottage
119 Sonadanga Thana Road
Mojid Saroni, Sonadanga, Khulna
Mobile: +88 01709 632890
E-mail: adex_khulna@adexbd.com

Bogura Office:

Rimu & Tanvir Monjil (1st Floor)
House - 2, Road - 1, Masjid Line
Upashahor Bazar, Bogura
Mobile: +88 01729 212188
E-mail: adex_bogra@adexbd.com

Cumilla Office:

32/ka Tri-Ratno (3rd Floor)
Islampur, Fousdari Chowmohoni
Judge Court Road, Cumilla
Mobile: +88 01708 499990
E-mail: adex_comilla@adexbd.com

Factory:

Unit-1: Holding No. 3060/3798
West Dogri, Bhawal Mirzapur
Unit-2: J.L No. 6, Mouja: Dogri
Union: Mirzapur, Gazipur, Bangladesh
E-mail: ael_works@adexbd.com

