

Adex Transfo : NIRVOY

Oil Immersed Transformers

MV/LV Distribution Transformers ≤ 3150 kVA

Ground mounted

Oil immersed transformers

100kVA to 3150kVA

Frequency 50Hz-IEC standards



Standards

These transformers comply with the following standards:

- IEC 60076 and EU regulation No.: 548/2014

After years of continuous Research, Development and Testing, **ADEX R & D team** has developed and validated quality performance of these range of products.



NIRVOY - Normal Distribution Transformers

MV/LV Distribution oil immersed transformers
 ≤3150 kVA



Description

This range consists of transformers complying with the following specifications:

- Three-phase transformers, for indoor or outdoor use (installation to be specified).
- Step-down type. step-up on request
- Rated frequency . 50Hz
- Maximum ambient temperature: 40°C
- Mineral oil immersed (other dielectric upon request)
- Breathing type hermetically sealed transformers with integral filling
- Cover bolted on tank
- ONAN type natural cooling
- Standard anti-corrosion surface treatment and coating
- Final colour adex beige.

Basic fittings for Breathing type

Each transformer includes

- 1 off-circuit tappings switch with pad locking located on the cover, this switch operates on the highest rated voltage to bring the transformer to the supply voltage/actual value:
- Oil conservator
- Oil level gauge
- 3 MV porcelain bushing
- 4 LV flat bars
- earthing terminals on the cover
- 4 bi-directional rollers
- 2 lifting lugs
- 1 rating plate to be fixed on LV side
- 1 filling plug oil draining device
- Protection index IP 00, IP215 as option.

Routine tests

Routine tests are carried out on transformers during manufacture. Each transformer is issued with an official test certificate:

- Applied voltage dielectric test (50Hz-1mn)
- Measurement of:
 - no load losses and no load current
 - MV & LV winding resistance
 - impedance voltage and load losses
 - the transformation ratio & vector group.
 - dielectric strength of oil

Standards

These transformers comply with the following standards.

- IEC 60076 and EU regulation no.: 548/2015

Adex guarantees its transformers from manufacturing defects and all transformers are despatched after full routine tests.

Options

The following fittings may be provided as an option:

- 3 LV fixed plug-in-connectors
- 4 LV porcelain bushings
- LV cable connection box
- Locking device
- Hermetically sealed transformers with integral fillings
- Control & Protection devices
- Buchholz relay or a protection relay DGPT2 Including:
 - 1 gas detector / low level indicator with one contact
 - 1 over pressure contact
 - 2 thermostats for alarm & tripping
 - 1 dial type thermometer indicator

Adex-transfo																										
test certificate n° 71156356-02																										
Product		: Ground mounted distribution transformer			Rated power		: 630 kVA																			
Type		: Step down- outdoor- Three-phase			Rated frequency		: 50 Hz																			
Standard		: IEC 60076			Total mass		: 1965 kg																			
Dielectric		: Oil			Mass of dielectric		: 423 kg																			
Type of cooling		: ONAN			Year		: 2013																			
Maximum ambient according to IEC 76		: 40 °C			Altitude service : X < 1000 m																					
Maximum dielectric temperature rise		: 50 °K																								
Maximum winding temperature rise		: 65 °K																								
Rated voltage		: HV 6600 V			Currents : 55,11 A																					
Tappings		: HV 6980 V - 6765 V - 6435 V - 6270 V																								
Insulation		: 12 kV(75/28)			Applied voltage : 28 kV		Duration : 60 s																			
Rated voltage		: LV 415 V			Currents : 676,5 A																					
Insulation		: 1,1 kV (0,3)			Applied voltage : 3 kV		Duration : 50 s																			
Convection : D yn11					Insulated voltage : 13200 V		Duration : 30 s		Frequency : 200 Hz																	
Remarks		: Thermic class A Test procedure No MCD/SAV/ESS/05 - Tightness test 100 g/cm ² /6 h min satisfactory. Adex Transfo guarantees that the PCB content of the mineral oil used in its new transformers is below the detection level specified in IEC 597 standardized method, i.e. 2ppm Hermetically sealed and completely filled																								
Guaranteed		Po	I/IN	PCC at 75°C	UCC at 75°C	Po+PCC at 75°C	Transformation																			
		6300 W		6,00%		7350 W	14,21%	0,330%	Principal tapping	Other ± 1%																
Rated voltage ratio		Resistances at 18,0 °C																								
1- 16,70		HV : 0,670 Ω			LV : 0,00175 Ω																					
2- 16,30		0,660 Ω			0,00178 Ω																					
3- 15,90		0,653 Ω			0,00178 Ω																					
4- 15,51		Average 0,671 Ω			0,00175 Ω																					
5- 15,10		Δ R12 : 3056 W			2020 W																					
		Δ R12 75°C : 3744 W			2474 W																					
No-load losses		Results																								
Hz	U(V)	I(A)	IS(A)	IS(A)	I(A)	dW1 ± dW2	cte	k	Po	Δ Po I	I/IN	I/IN														
50	415	3,22	2,37	3,08	2,89	967	1		967 W	14,21%	0,330%															
Load losses at 18,0°C (W+LV)		Results at 75 °C																								
LV1	I1(A)	D1(A)	I1(A)	cte	dW1±dW2	cte	k	Pmos	PCC	Δ PCC	UCC	Δ UCC														
373,0	55,08	55,10	55,14	1	5761	1		5761	6777 W	4,28%	5368%	-5,35%														
373,0																										
Issued on 01/08/2013		<table border="1"> <tr> <td>Po+PCC</td> <td>7752 W</td> <td>Δ Po+PCC</td> <td>5,48%</td> </tr> <tr> <td>Efficiency</td> <td>cos φ 0,8 : 98,485 %</td> <td>cos φ 0,8 : 4,279 %</td> <td></td> </tr> <tr> <td></td> <td>cos φ 1,0 : 98,754 %</td> <td>cos φ 1,0 : 1,231 %</td> <td></td> </tr> </table>													Po+PCC	7752 W	Δ Po+PCC	5,48%	Efficiency	cos φ 0,8 : 98,485 %	cos φ 0,8 : 4,279 %			cos φ 1,0 : 98,754 %	cos φ 1,0 : 1,231 %	
Po+PCC	7752 W	Δ Po+PCC	5,48%																							
Efficiency	cos φ 0,8 : 98,485 %	cos φ 0,8 : 4,279 %																								
	cos φ 1,0 : 98,754 %	cos φ 1,0 : 1,231 %																								
Tested by																										
ADEX ENGINEERING LIMITED		Head Office : 53 Purana Pallan (Gro Filler), Dhaka-1000, Bangladesh. Phone: 886 886, 955 9526, 95562626, Fax: 02-4962705 e-mail: info@adexbd.com, www.adexbd.com																								
		Factory : West Dugri, Bhalwal Mirzapur, Gazipur Bangladesh. Phone : 01713164508																								

Insulation (kV)	7.2	12
kVrms 50Hz-1mn	20	28
kV BIL 1.2/50µs	60	75

NIRVOY - Normal Distribution Transformers

MV/LV Distribution oil immersed transformers ≤ 3150 kVA

Electrical characteristics: Ecodesign to EU regulation no.: 548/2014

rated power (kVA)		160	250	315	400	500	630	800	1000	1250	1600	2000	2500	3150
rated voltage	primary	12kV												
	secondary at no-load	415V between phases, 240V phase to neutral												
rated insulation level		12kV for 11kV												
HV tapping range(off voltage)		$\pm 2.5\%$, $\pm 5\%$												
vector group		Dyn11												
losses	no - load	210	300	360	430	510	600	650	770	950	1200	1450	1750	2200
	load	2350	3250	3900	4600	5500	6500	8400	10500	11000	14000	18000	22000	27500
rated impedance voltage (%)		4	4	4	4	4	4/6	6	6	6	6	6	6	6
voltage drop at full load (%)	p.f= 1	1.25	1.14	1.03	0.99	1.06	1.19	0.9	0.93	0.85	0.8	0.78	0.7	0.7
	p.f = 0.8	3.12	3.21	3.15	3.109	3.8	4.9	4.78	4.78	4.82	4.15	4.2	4.8	4.76
efficiencies (%)	p.f =1 at 100% load	98.48	98.62	98.8	99.08	98.9	98.64	98.97	98.94	99.01	99.13	99.11	99.16	99.15
	p.f = 0.8 at 100% load	98.11	98.28	98.6	98.85	98.5	98.3	98.72	98.68	98.76	98.92	98.89	98.96	98.96

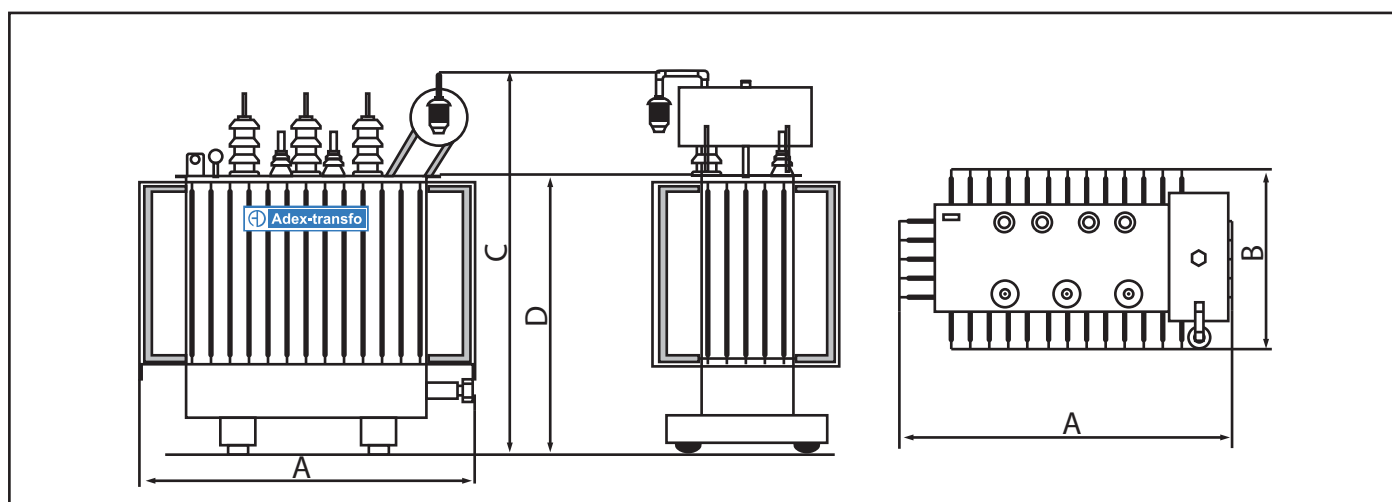

Dimensions and weights

Typical dimensions and weights are indicated in the table below for mineral oil immersed transformers.

They are provided for 12kV/415 V transformers with electrical characteristics, as described in the previous table.

For other electrical characteristics (voltage, losses. etc...) or other dielectric, dimensions and weights would be different (please consult us).

N.B: The terminal marking is in accordance with IEC standards 616 (1978) see attached diagram.

Approximate dimensions (mm).

KVA	100	160	200	250	315	400	500	630	800	1000	1250	1600	2000	2500	3150
A	965	1065	1125	1161	1235	1285	1319	1391	1595	1619	1739	1757	1988	2100	2250
B	495	555	574	593	660	556	659	683	818	846	899	905	1043	1110	1350
C	1165	1246	1243	1255	1276	1486	1558	1788	1902	1779	1931	2050	2136	2200	2274
D	765	846	843	855	876	1086	1158	1288	1402	1279	1431	1500	1576	1700	1714
Flat bars weights (kg) total	712	881	1003	1074	1340	1620	1977	2423	2900	3083	3920	4585	5668	6032	6100
mineral oil	181	200	215	235	287	407	455	557	710	712	959	1107	1286	1514	1658

Note: Dimension may change depending on the electrical parameter as per final design at the time of order acknowledgement.

NIRVOY - Hermetically Sealed Transformer

MV/LV Ecodesign distribution transformers ≤ 3150 kVA

Introduction

Hermetically sealed transformer is an oil immersed transformer suitable in contaminated areas and climate with high humidity. In hermetically sealed transformers, the oil pressure is higher than the atmospheric pressure and unlike the conservator type transformers, the tank of these transformers act as a pressurized vessel. Due to lack of any contact between oil and environment, aging of oil will be deferred and the transformer encounter lower risk in comparison with conservator type transformers.

The tank of hermetically sealed transformers must tolerate high pressure. Due to elimination of conservator, oil temperature variations lead to expansions and contraction of transformer tank and so this affects transformer tank design, behaviour and aging.

Transformer tank are manufactured in corrugated form for efficient heat transfer and oil cooling. In hermetically sealed transformers, the ribs of corrugated tank have the essential role in cooling and tolerating pressure variations.

Characteristics

This range consists of transformers complying with the following specifications:

- Rated power from 100 up to 3150 kVA, operating voltages up to 36 kV
- Three phase transformers, for indoor or outdoor use;
- Step down / Step up type
- Rated frequency 50/60Hz
- Hermetically sealed with integral fittings
- Tapping range on primary voltage: $\pm 2 \times 2,5\%$ or according to customer request
- Maximum ambient temperature 40°C;
- Maximum temperature rise of winding 65 K, top oil 60 K, natural air cooling (ONAN)
- Maximum installation altitude 1000 m above sea level
- Cover bolted on tank
- 2 loss ranges: normal losses and low-loss Ecodesigned
- Standard anti-corrosion surface treatment and coating
- Completely immersed in mineral oil in accordance with standard IEC 60296.

Standards

Our transformers comply with:

- Normal loss according to IEC 60076 standards
- Energy Efficient Ecodesign according to IEC and EU regulation No.: 548/2014

Specific Standards according to country requests etc. can also be complied with

- standards EN, ANSI, IEEE etc upon request
- other ambient (45°C, 50°C, 55°C etc) upon request.
- other rated frequency (60Hz) upon request.

For customization please consult us.



Advantages

- No aging of the dielectric liquid as there is no contact with the air.
- Minimal maintenance required.
- Compact size (specially suitable for low height areas).
- No expansion tank or air dehydrating needed
- Lighter in weight.
- Less dielectric liquid used than in other types of transformer.
- Minimal risk of leakages
- PCB (Polychlorinated biphenyls) free

Standard equipment

- mineral insulating oil IEC 60296
- Off-circuit regulation tap changer (can only be operated without voltage) IEC 60214
- MV porcelain bushings (plug-in connectors as optional)
- LV porcelain bushings/plug in
- 4 LV flat bars from 250kVA
- 2 Earthing terminals in the tank
- Draining device
- Rating plate EN 50464-1
- 2 Lifting and untanking lugs;
- 4 bidirectional flat rollers from 160kVA;
- filling plug;
- Thermometer pocket ;
- Wheels

Options

- 3 HV plug-in connectors HN 52 S 61 250A/24kV , straight or elbow
- Thermometer: measures the temperature of the top layer of the insulation liquid.
- Available with 2 contacts (alarm and trigger) and upper limit marker
- DMCR 3.0 Protection relay
 - over pressure detection
 - over temperature detection & temperature indication
 - over temperature primary/ alarm
 - over temperature secondary tripping
 - di-electric level monitoring & gas detection

NIRVOY- Ecodesigned Liquid Immersed Transformers

 7.2 kV and 12 kV A₀B_k

Electrical characteristics: Ecodesign to EU regulation no.: 548/2014

rated power (kVA)		160	250	315	400	500	630	800	1000	1250	1600	2000	2500	3150
rated voltage	primary	12kV												
	secondary at no-load	415V between phases, 240V phase to neutral												
rated insulation level		12kV for 11kV												
HV tapping range(off voltage)		± 2.5%, ± 5%												
vector group		Dyn11												
losses	no - load	210	300	360	430	510	600	650	770	950	1200	1450	1750	2200
	load	2350	3250	3900	4600	5500	6500	8400	10500	11000	14000	18000	22000	27500
rated impedance voltage (%)		4	4	4	4	4	4/6	6	6	6	6	6	6	6
voltage drop at full load (%)	p.f= 1	1.25	1.14	1.03	0.99	1.06	1.19	0.9	0.93	0.85	0.8	0.78	0.7	0.7
	p.f = 0.8	3.12	3.21	3.15	3.109	3.8	4.9	4.78	4.78	4.82	4.15	4.2	4.8	4.76
efficiencies (%)	p.f =1 at 100% load	98.48	98.62	98.8	99.08	98.9	98.64	98.97	98.94	99.01	99.13	99.11	99.16	99.15
	p.f = 0.8 at 100% load	98.11	98.28	98.6	98.85	98.5	98.3	98.72	98.68	98.76	98.92	98.89	98.96	98.96

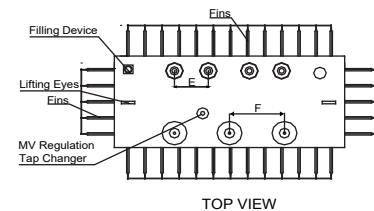
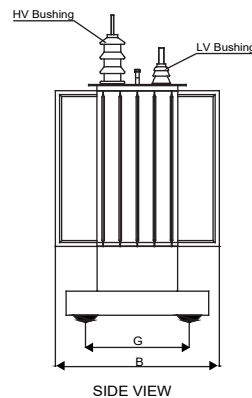
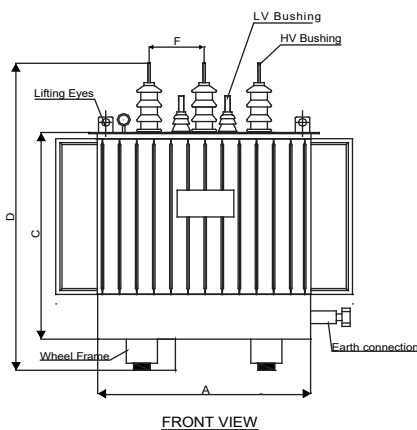

Dimensions (mm) - Ecodesign

rated power (kVA)		160	250	315	400	500	630	800	1000	1250	1600	2000	2500	3150
A (length)		1125	1375	1410	1540	1625	1750	1850	1930	1980	2000	2200	2350	2390
B (width)		800	875	660	900	910	925	1120	1145	1400	1405	1540	1610	1850
C (height to cover)		845	950	1010	1085	1125	1160	1290	1400	1395	1560	1570	1630	1770
D (height to HV porcelain bushings)		1195	1300	1360	1435	1510	1640	1800	1795	1960	1970	2080	2220	2220
E (separation between LV bushing)		150	150	150	150	150	150	150	160	160	160	160	160	160
F (separation between HV bushings)		265	265	265	265	265	265	265	265	265	265	265	265	265
porcelain LV(A)		250	630	630	1000	1000	1600	1600	2500	2500	3150	3150	5000	5000
G (distance between wheel axis)		670	670	820	820	820	820	820	1020	1020	1020	1020	1450	1450
wheel diameter		125	125	125	125	125	125	125	125	125	125	200	200	200
height of wheel		40	40	40	40	40	40	40	40	40	40	60	60	60
weights (kg):	mineral oil	200	260	280	330	390	410	510	630	740	1000	1200	1400	1630
	total	780	1030	1200	1350	1620	1770	2270	2460	2790	3890	4790	5400	6390

General

Our Quality System

All Adex Transfo are manufactured in accordance with the quality system as per ISO 9001: 2015.

The quality system is aimed at achieving customer satisfaction in terms of design, quality, service, and adaptation of equipment in line with technology.

The process includes the manufacturing flow chart, internal audit, control non-conforming product, corrective action, quality checking, quality of suppliers and others.

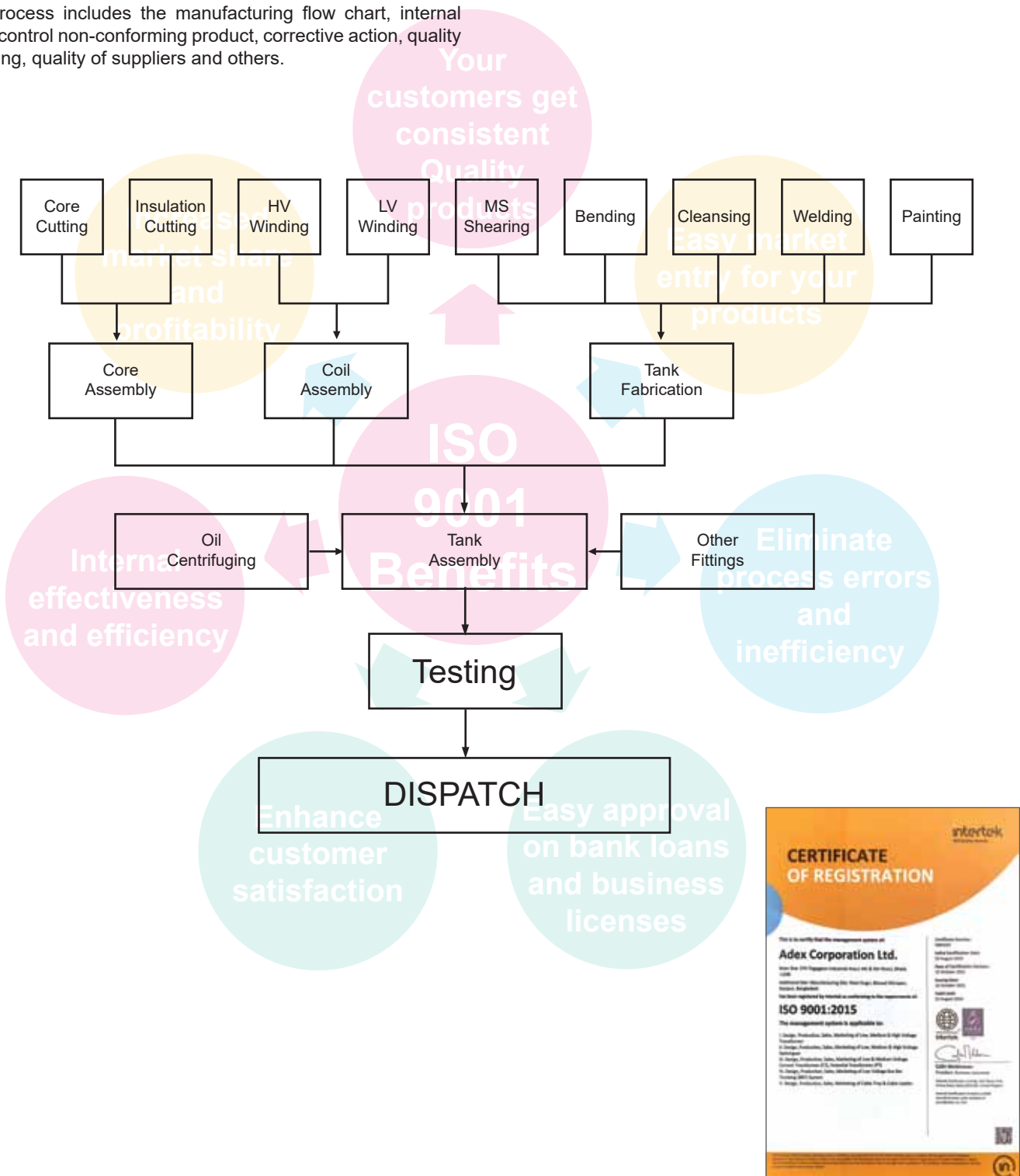

General

Our Transformers

- Optimised to withstand short circuit forces
 - Concentric windings
 - Insulation between layers
 - Coils are manufactured using the latest techniques and machinery

- Improved heat dissipation in the windings
 - Expertise in coil cooling
 - Careful manufacturing of coils and cooling channels

- Guaranteed insulation
 - Use of high-quality cellulosic materials
 - Optimum handling
 - Storage to preserve insulation properties
 - Connections and Tap Changer

- MV and LV terminals
 - Transformer connection to the outside

- Off-circuit Tap changer
 - Secondary voltage can be adjusted precisely

- Elastic Corrugated tank with cooling fins
 - Increased heat dissipation surface

- Immersed in dielectric liquid
 - Lower noise level
 - Better behaviour in the event of overloads and harmonics

- Surface treatment and paint
 - Protection against corrosion, atmospheric agents, insulation and impacts

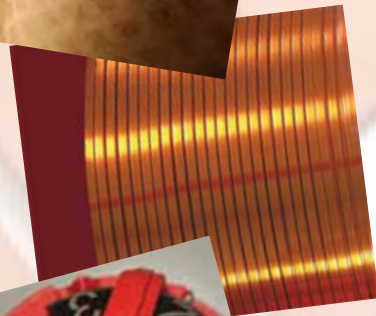

Production Facilities

PRODUCTION SITE

Adex transformer production sites are located in Gazipur, Bangladesh with a capacity of producing 750000 kVA transformers per year.

The factory has been organised with advance technology and with the consideration of project design stage to the dispatch of finished goods.

Adex Engineering Limited

Production:

- PROTIVA - Ecodesign cast resin transformer $\leq 3150\text{kVA}$
- NIRVOY - Ecodesign liquid immersed transformer $\leq 3150\text{kVA}$
- Standard oil immersed transformer (100kVA to 3150kVA, 36kV)
- Hermetically sealed transformer (100kVA to 3150kVA, 36kV)
- Power transformers (upto 35MVA, 132kV)
- Cast resin transformer (upto 5MVA, 316kV)



ADEX Engineering Ltd. world class CNC operated factory

Production Facilities

Technological Development

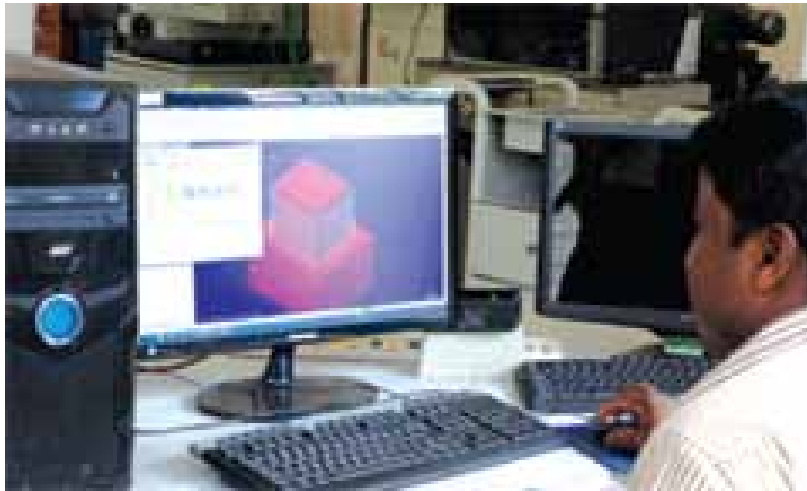

To ensure manufacturing reliability it is important for design and production department to be linked. We facilitate this by our skilled design team and modern digitized machines for different sections of production.



Production Facilities

Iron Core



The iron core is made of cold rolled grain oriented, low loss and high magnetic conductive silicon steel sheet.

The magnetic cores are precisely cut from very wide sheets of electrical steel using a series of slitters and core cutting machines enabling dust free production field for active parts.



Machines are CNC controlled which gives more accuracy and help us obtaining right properties in the material.

Stacking tables for facilitating the standard technique of step lap stacking to reduce core loss and noise level.



Production Facilities

Winding

Winding is the most important and sensitive part of transformer. Their design and construction decide transformer's parameters demanded by customers.

This section consists series of winding machines for HV,MV and LV coils for all types of conductors,strips and round wires.

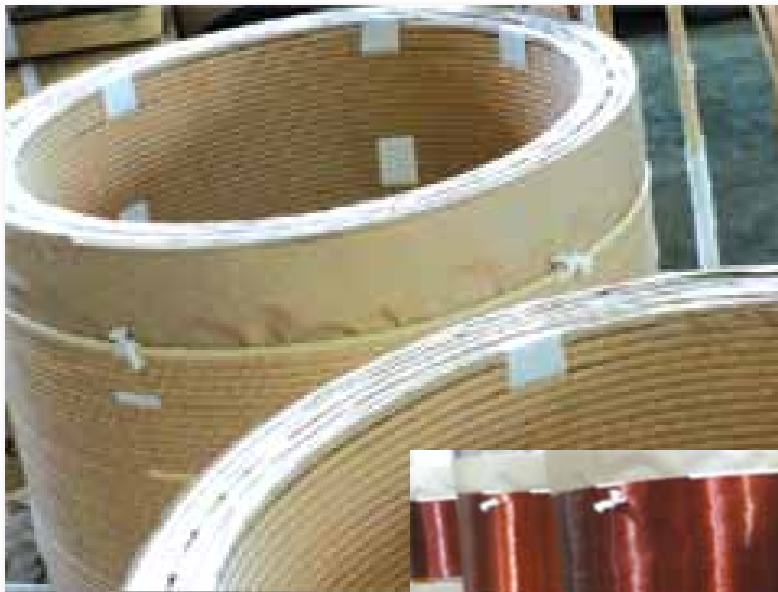

Low voltage windings are generally layer, helical or disc type. For high voltage windings, flat enamel conductors are used in layer or disc winding technique depending on the voltage and current.

The technologies used are copper or aluminium windings providing transformer its short-circuit strength in accordance with current standards.

Production Facilities

Drying

Before being placed in the tank, the active part are dried up using vacuum drying oven for removal of moisture and other impurities. It is crucial requirement in transformer ensuring trouble free operation through the life span of the transformer.



Oil

The most commonly used dielectric liquids are of mineral oil type . For purification and filtration, we facilitate oil to be centrifuged by oil centrifuging machine. To control the chemical properties of the insulating material we do testing in our testing laboratory.

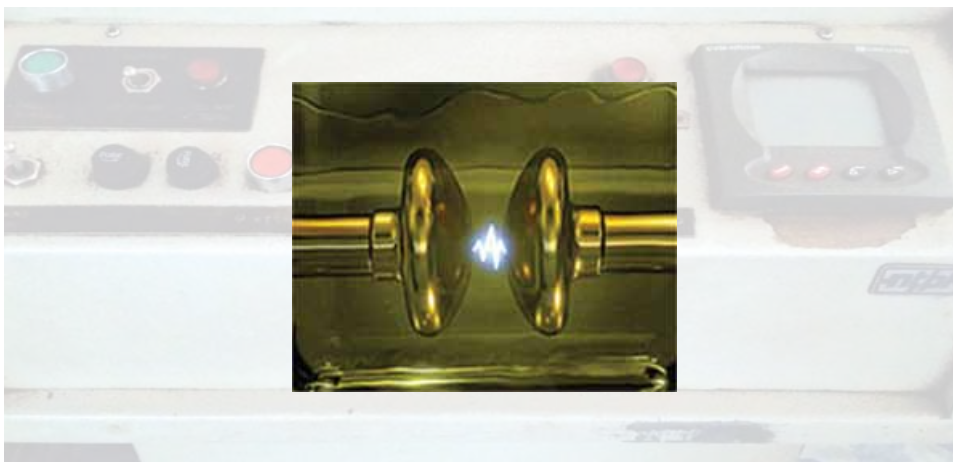

Production Facilities

Tank

For mechanical production, we have advanced technology facilities like plazma cutting , fin forming machines and etc for making different parts to maintain a high quality.



Higher priority is given to welding and surface treatment.



*ADEX guarantees that its TRANSFORMERS
are manufactured with all new materials
and is totally free from second hand parts
polluted with PCB's*

ADEX ENGINEERING LIMITED.

Corporate Office:

374 Tejgaon I/A (4th & 5th Floor)
Dhaka-1208, Bangladesh.
Tel: +88-02 - 55029737, 55029738
E-mail: info@adexbd.com

Chattogram Office:

bti Kanchan, Flat - A2, House - 25
Road - 2, O.R Nizam Road R/A
GEC Circle, Chattogram – 4000
Phone: +88 01713 436281
E-mail: adex_ctg@adexbd.com

Sylhet Office:

Natun Bridge, Shayestagonj
Station Road, Hobigonj
Mobile: +88 01708 499990
E-mail: adex_sylhet@adexbd.com

Khulna Office:

Mirza Cottage
119 Sonadanga Thana Road
Mojid Saroni, Sonadanga, Khulna
Mobile: +88 01709 632890
E-mail: adex_khulna@adexbd.com

Bogura Office:

Rimu & Tanvir Monjil (1st Floor)
House - 2, Road - 1, Masjid Line
Upashahor Bazar, Bogura
Mobile: +88 01729 212188
E-mail: adex_bogra@adexbd.com

Cumilla Office:

32/ka Tri-Ratno (3rd Floor)
Islampur, Fousdari Chowmohoni
Judge Court Road, Cumilla
Mobile: +88 01708 499990
E-mail: adex_comilla@adexbd.com

Factory:

Unit-1: Holding No. 3060/3798
West Dogri, Bhawal Mirzapur
Unit-2: J.L No. 6, Mouja: Dogri
Union: Mirzapur, Gazipur, Bangladesh
E-mail: ael_works@adexbd.com

